

PASSIVE MIDDLE EAR IMPLANTS

VENTILATION TUBES
SURGICAL INSTRUMENTS



MIDDLE EAR INTELLIGENCE

KURZ Medizintechnik	KURZ Medizintechnik	5
	KURZ Middle Ear Prostheses	6
	Implant Materials and Processing	7
Implant Systems and Prostheses for Tympanoplasty	Overview	8-9
	TTP-VARIAC® System	10-11
	TTP®-VARIO System	12
	TTP®-Tuebingen Type Prostheses	13
	Duesseldorf Type Prostheses	14
	Munich ^{LMU} Type Prostheses	15
	MNP Malleus Notch Prostheses	16
	MRP Malleus Replacement Prosthesis	17
	OMEGA CONNECTOR	18-19
	CliP® Partial Prosthesis Dresden Type	20
	CliP Partial FlexiBAL® Prosthesis	21
	Angular CliP® Prosthesis	22
	Angular Prosthesis Plester	22
	Regensburg Type Total Prosthesis	23
Prostheses for Stapedioplasty	Overview	24-25
	MatriX Stapes Prosthesis	26
	K-Piston Stapes Prosthesis	27
	Skarzynski Piston Stapes Prosthesis	28
	Angular Piston Stapes Prosthesis	29
	NiTiFLEX Stapes Prosthesis	30
	Soft CliP® Stapes Prosthesis	31
	CliP® Piston aWengen Stapes Prosthesis	32
	CliP® Piston MVP Stapes Prosthesis	33
	Bucket Type Stapes Prosthesis	34
	NiTiBOND® Stapes Prosthesis	36-37
Ventilation Tubes	Overview	38-39
	Tuebingen Type Ventilation Tubes	40
	Beveled Type Ventilation Tubes	41
	TVT Trocar Ventilation Tubes	42
	Ventilation Tubes with Eyelets	43
	Minimal Type Ventilation Tube	44
	Instruments and Accessories	Overview
TTP-VARIAC® System Accessories		48
AC ^{sizer} System Single-Use		49
KURZ® Precise Cartilage Knife		50
Cartilage Forceps Schimanski Design		51
Cartilage Punch		52
Sizer OMEGA CONNECTOR		53
Malleus Handle Cavity Bending Pliers		54
BELL Expander		55
KURZ® Meter		56
Soft CliP® Hook		57
Ventilation Tube Insertion Forceps	58	

First Choice in Passive Middle Ear Implants

KURZ MEDIZINTECHNIK

For more than 30 years now, KURZ Medizintechnik has stood for ground-breaking developments in the middle ear prosthetics with its implants, instruments and tympanostomy tubes.

HIGH-TECH FOR THE MIDDLE EAR

When the company founder Heinz Kurz started with a small golden tympanostomy tube in 1974, no one could foresee that KURZ implants would one day set the standards for middle ear prostheses and instruments worldwide. Today KURZ products are highly innovative, high-tech works of art, designed to comply with the smallest tolerances and material thicknesses.

From the beginning, the proximity to local universities was an important locational advantage for our company, as well as the density of highly specialized companies in southwest Germany. To this day, KURZ prostheses are manufactured exclusively at our locally owned and operated manufacturing facility with support from competent partners.

WORLDWIDE REPRESENTATION

We supply surgeons and clinics worldwide via a broad network of distribution partners and have an American based subsidiary Kurz Medical Inc., out of Atlanta, GA. Attention to detail is important in the care and handling of our products and therefore we believe in supporting the market place with the highest level of sophistication and professional ethics. KURZ hosts several clinical and academic training seminars globally conducted by leading specialists in middle ear surgery.

ENTHUSIASM FOR TECHNOLOGY

In our developmental efforts, we work closely with leading national and international scientists, surgeons and engineers. Our collective know-how, tireless creativity and inquisitive minds, focus on the realization of implant designs that are comparable to functional anatomy in hopes of providing our patients with the best possible hearing results whom our products are made for.

Additional information



KURZ Middle Ear Prostheses

WELL-ESTABLISHED KNOWLEDGE OF THE MIDDLE EAR

The aim of reconstructing the ossicular chain is to create the natural function as closely as possible and conduct the incoming acoustic signal to the inner ear with minimal loss. The complex mechanics of acoustic sound transmission places high demands on the development of implants and calls for well-established knowledge of the middle ear. Furthermore, prostheses must have properties that facilitate implantation for the surgeon and help to minimize risks.

SOLUTIONS FOR EVERY SITUATION

KURZ covers the entire range of implants required for tympanoplasty and stapedioplasty. In addition, the product line is rounded off by precision otological instruments and ventilation tubes.

INNOVATIVE DESIGNS AND MATERIALS

Innovative KURZ product designs and materials have set new standards in middle ear prosthetics throughout the world. For example, length adjustable prostheses can be shortened to a Functional Length of 0.75 mm. CliP prostheses standardize coupling to the incus or stapes. New types of ball-joint designs counterbalance the natural movements of the tympanic membrane and anatomically adapted bells create a secure connection to the stapes head. Furthermore, finely balanced weight distribution provides the prostheses with intraoperative stability.

These developments are based not only on well-established anatomical understanding but also on the latest results of scientific research and extensive test series. KURZ prostheses are available in numerous types and offer ideal solutions also in challenging anatomical situations.

MR information is available on www.kurzmed.com

IMPLANT MATERIALS AND PROCESSING

UTMOST CARE AND HIGHEST PRECISION

In order to achieve best possible results, the elegant design of the KURZ prostheses often probes the limits of feasibility. The manufacturing process of these prostheses requires highest precision and utmost care. Stringent inspections furthermore ensure compliance with highest quality standards.

INTENSIVE CLEANING PROCESS

All KURZ prostheses undergo an intensive cleaning process. The result is an extremely pure surface. This contributes toward ensuring irritation-free contact with the sensitive mucosa and helps to prevent inflammations and granulomas which can develop as a result of residues or dirt particles.

HIGH DEMANDS TO BE MET BY MATERIALS

For the production of their prostheses, KURZ uses only high-quality, clinically tested material: Due to its excellent biocompatibility titanium has since decades proven its worth as implant material. In addition, KURZ employs innovative nitinol variants which offer numerous clinically unique benefits.

MRI SAFETY TESTS

MRI safety tests also cover the compatibility of KURZ prostheses, as long-term implants, with potential future Tesla strengths (up to 7.0 T). For further MRI-related information, see www.kurzmed.com

NITINOL

Nitinol was discovered in 1958 by the Naval Ordnance Laboratory (USA). The alloy is made up of nickel and titanium in roughly equal proportions. It is distinguished by good mechanical properties as well as high resistance to corrosion.

Nitinol can assume different properties: As a shape memory alloy, the metal is malleable and returns to its pre-programmed state when heated. The KURZ NiTiBOND Stapes Prosthesis makes use of this closing effect.

Nitinol can also be produced in a superelastic configuration. These properties have been utilized in the design of the NiTiFLEX Stapes Prosthesis. The CliP attachment exhibits extreme spring elasticity and gently couples to the long process of the incus.

TITANIUM

KURZ uses only high-quality (ASTM F67, medical grade), pure titanium for their prostheses. The properties of this material grade are ideally suited due to its rigidity, weight and technical manufacturing possibilities. The biocompatibility of this metal is also suitable for long-term applications.

Thanks to its low mass, titanium is particularly suitable for the use in middle-ear prosthetics. Compared to other materials, it minimizes losses in connection with the transmission of sound energy. Moreover, the material is extremely resistant to deformation, while at the same time it can, if required, be adapted to individual anatomical situations by bending.

References:

Wirsching K., Lehle K., Jacob P., Gleich O., Strutz J., Kwok P. Influence of Surface Processing on the Biocompatibility of Titanium. Materials 2011, 4(7), 1238-1248; doi: 10.3390/ma4071238

PURE TITANIUM (ASTM F67): CHEMICAL COMPOSITION				
Element	Grade 1	Grade 2	Grade 3	Grade 4
Titanium (Ti)	99.48	99.31	99.19	98.94
Nitrogen (N)	0.03	0.03	0.05	0.05
Carbon (C)	0.10	0.10	0.10	0.10
Hydrogen (H)	0.0125	0.0125	0.0125	0.0125
Ferrite (Fe)	0.20	0.30	0.30	0.50
Oxygen (O)	0.18	0.25	0.35	0.40

Maximum cut-off grades in % (m/m)

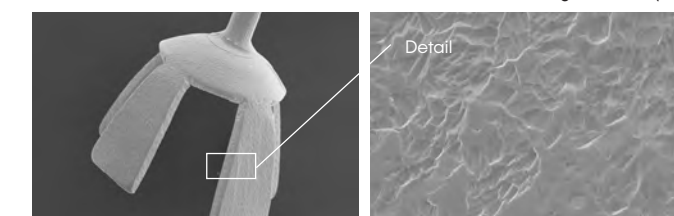

BELL after cleaning. 50 times magnification (KURZ Prosthesis)

Titanium surface after cleaning. 1000 times magnification (KURZ Prosthesis)

IMPLANT SYSTEMS AND PROSTHESES FOR TYMPANOPLASTY



ELEGANT DESIGNS WITH INNOVATIVE FEATURES

KURZ implant systems and prostheses for tympanoplasty are elegantly designed made from pure titanium. Well-established understanding of middle ear mechanics, in conjunction with the latest clinical research, represents the basis of our innovative developments. KURZ products are subject to extensive measurement and simulation testing. Furthermore, there are numerous publications by independent surgeons reporting the positive experiences with KURZ products.

SHORTEST FUNCTIONAL LENGTHS

KURZ designs all our devices considering pre-tension and stability such that the acoustic signal is transferred most optimal across the hearing frequencies. Consequently, a broad length availability becomes focal and in particular short length prostheses.

All KURZ partial prostheses achieve a functional length of 0.75 mm including our adjustable TTP-VARIO and TTP-VARIAC systems. Engineering was able to eliminate size limiting fixation columns from underneath the headplate by introducing a unique locking mechanism inside the headplate itself bringing greater utility and eliminate the need for additional shelf stock*.

OPTIMIZED INTRAOPERATIVE HANDLING

During surgery the finely balanced weight distribution of KURZ prostheses, and partially roughened surfaces, provide additional stability in handling. Fine structures and large, fenestrated head plates help to achieve better intraoperative visibility.

KURZ designs are also engineered to compensate for negative side effects of the healing process as found in the FlexiBAL partial pros-

thesis with its micro ball joint in the head plate. This flexibility mimics the fine movements of the tympanic membrane especially during the healing phase which has a favorable impact on implant stability.

BELLS, CLIPS, AND ADHESION FORCES

KURZ has developed many different solutions to ensure optimal, standardized coupling to the stapes head and footplate:

The conically shaped bell of the partial prostheses optimally adapts to the stapes head encouraging acoustic transfer function in the direction of the oval window. Recessed slots allow adequate space for the stapedius tendon and are easily augmented in the presence of superstructure anomaly.

The CliP partial prosthesis features spring loaded, atraumatic foils that create unprecedented stability and standardized coupling to the stapes head. Especially in the case of extensive tympanic membrane reconstructions the filigree clip legs of the original KURZ CliP provide additional security and stability, particularly in long-term use.

Each KURZ total prosthesis is designed with a cannulated distal footing developed to give the prosthesis an excellent degree of stability. Additional stability and function is accessed when the hollow stem of the Total Prosthesis is cupped over the OMEGA sphere, transforming a typically static coupling to a much more dynamic union. In this way a flexible ball joint connection is created which can follow the postoperative movements of the tympanic membrane in the healing phase.

* Neudert M., Bornitz M., Lasurashvili N., Schmidt U., Beleites T., Zahnert T.: Impact of Prosthesis Length on Tympanic Membrane's and Annular Ligament's Stiffness and the Resulting Middle Ear Sound Transmission. *Otology & Neurotology*: HYPERLINK "http://journals.lww.com/otology-neurotology/toc/2016/10000" October 2016, Volume 37, Issue 9 p e369-e376. doi: 10.1097/MAO.0000000000001064

ADJUSTABLE LENGTHS



TTP-VARIAC System Partial

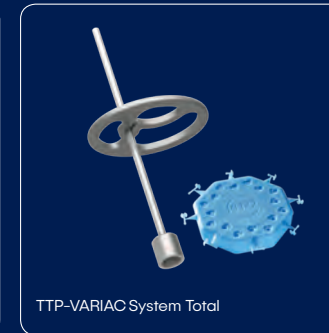

TTP-VARIAC System Total

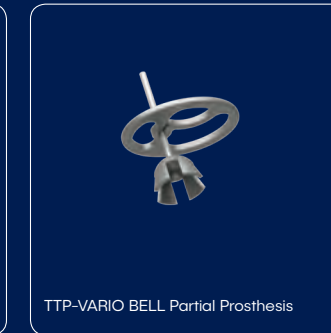

TTP-VARIO BELL Partial Prosthesis

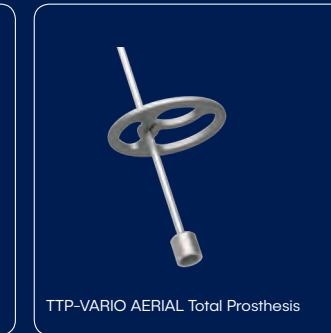

TTP-VARIO AERIAL Total Prosthesis

FIXED LENGTHS

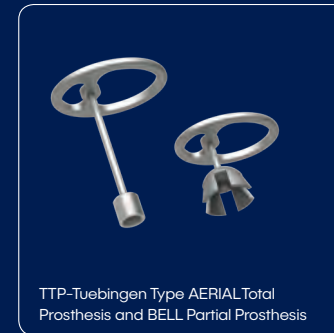

TTP-Tuebingen Type AERIAL Total Prosthesis and BELL Partial Prosthesis



Duesseldorf Type AERIAL Total Prosthesis and BELL Partial Prosthesis



MNP Malleus Notch Total and Partial Prostheses

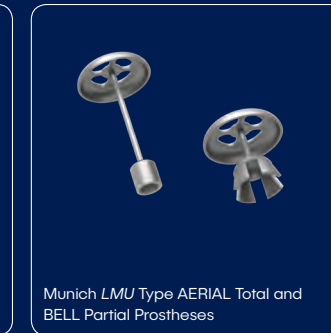

Munich LMU Type AERIAL Total and BELL Partial Prostheses



CliP Partial FlexiBAL Prosthesis

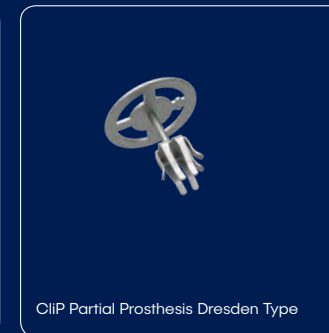

CliP Partial Prosthesis Dresden Type



Angular CliP Prosthesis



Angular Prosthesis Plester

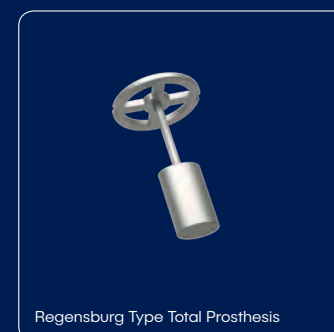

Regensburg Type Total Prosthesis

OPTIONS



OMEGA CONNECTOR

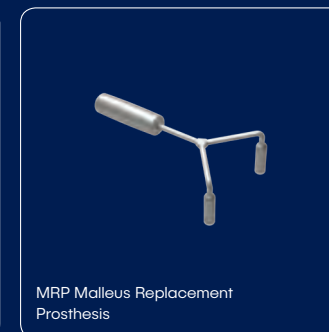

MRP Malleus Replacement Prosthesis

TTP-VARIAC® SYSTEM

Adjustable Length Prostheses

MAXIMUM VARIABILITY

The tension-sensitive annular ligament of the stapes footplate plays a key role in reconstruction of the ossicular chain: If undesirable pretension develops here, it can have a critical effect on postoperative hearing outcome. Short prosthetic solutions as short as 0.75 mm Functional Length are available to counteract against unintentional tension.

HIGH-PRECISION PATENTED SYSTEM

The TTP-VARIAC System provides variability that is unique throughout the world: It is comprised of two variable-length titanium prostheses (one Partial, one Total) and the multifunctional ACSizer Disk. With the aid of different sizes of Sizer attached to the latter the surgeon can determine the required length of prosthesis with precision. On account of the patented clamping mechanism directly within the head plate the implant can be shortened to a Functional Length of up to 0.75 mm and the head plate can be fixed to the stem securely.

PROVEN BENEFITS OF KURZ TYMPANOPLASTY PROSTHESES

Like all KURZ prostheses, the TTP-VARIAC System has proven benefits: The elegant design and a fenestrated head plate provide maximum intraoperative visibility. The partially roughened surface improves stability.

TWO PROSTHESES FOR ALL LENGTHS

The high flexibility of the TTP-VARIAC System ensures not only the most appropriate length in each case. It also makes a major contribution to the optimization of inventory levels. One ideal addition to the total prosthesis model is the OMEGA CONNECTOR (see page 18-19).

Developed in close collaboration with Tuebingen University ENT Clinic, Germany.

Voss, S. E., Nakajima, H. H., Huber, A. M., & Shera, A. C. (2013). Function and Acoustics of the Normal and Diseased Middle Ear. In Puria, S., Fay, R. R. & Popper, A. (Eds). The Middle Ear. Science, Otolaryngology, and Technology. Chapter 4. New York, Heidelberg, Dordrecht, London: Springer.

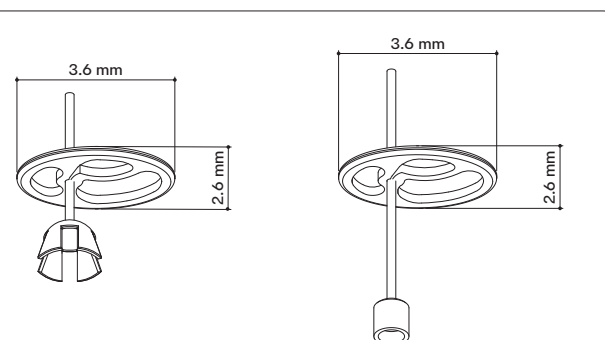
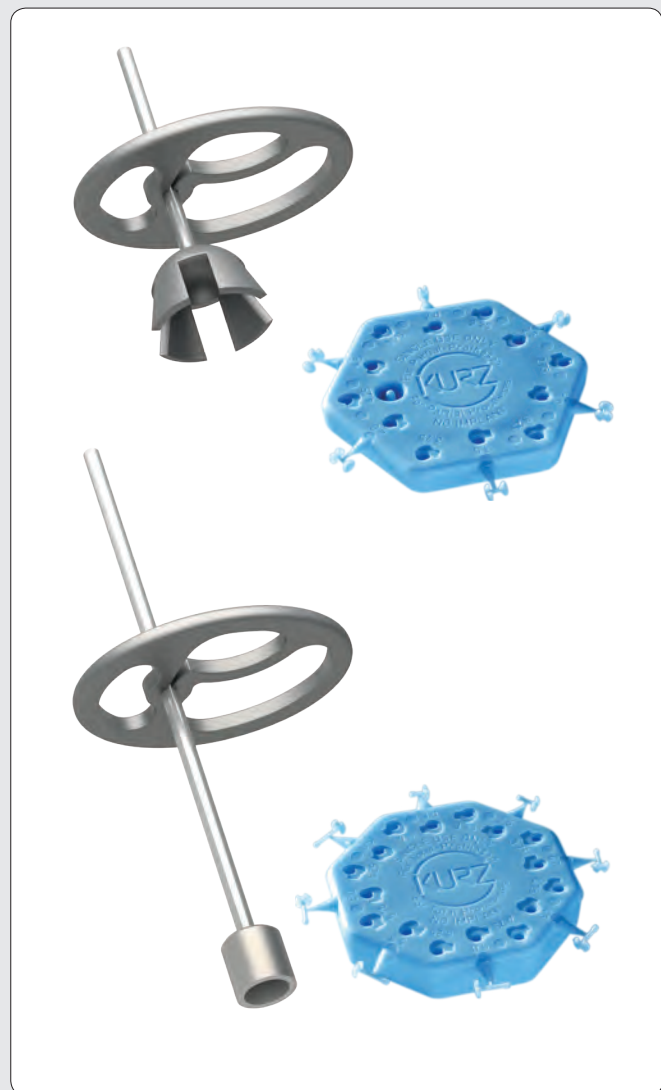

TTP-VARIAC System
Partial Prosthesis
Material:
Pure Titanium (ASTM F67
Medical Grade)
Shaft Diameter: 0.2 mm

TTP-VARIAC System
Total Prosthesis
Material:
Pure Titanium (ASTM F67
Medical Grade)
Shaft Diameter: 0.2 mm

ITEM	REF
TTP-VARIAC System Partial (Prosthesis and Sizer-Disk) Adjustable Length 1.75 - 4.50 mm (in 0.25 mm increments) Functional Length (FL) 0.75 - 3.50 mm	1002 020
TTP-VARIAC System Total (Prosthesis and Sizer-Disk) Adjustable Length 3.0 - 7.0 mm (in 0.25 mm increments)	1004 020

The TTP-VARIAC System Total Prosthesis is compatible with the OMEGA CONNECTOR (REF 1004 930).

Neudert M., Bornitz M., Lasurashvili N., Schmidt U., Beleites T., Zahnert T.: Impact of Prosthesis Length on Tympanic Membrane's and Annular Ligament's Stiffness and the Resulting Middle Ear Sound Transmission. Otolaryngology & Neurotology: [HYPERLINK "http://journals.lww.com/otology-neurotology/toc/2016/10000"](http://journals.lww.com/otology-neurotology/toc/2016/10000) October 2016, Volume 37, Issue 9 p e369-e376. Doi: 10.1097/MAO.0000000000001064



Additional information



SIZER-DISK FOR PARTIAL PROSTHESES

With integrated BELL Expander for expanding the bell

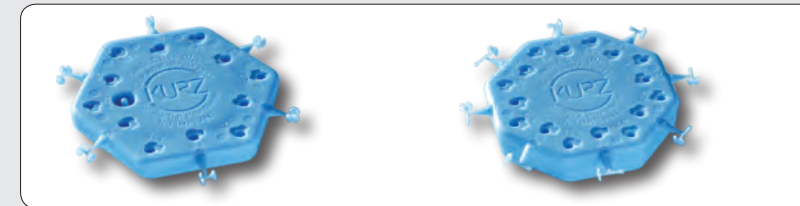

SIZER-DISK FOR TOTAL PROSTHESES

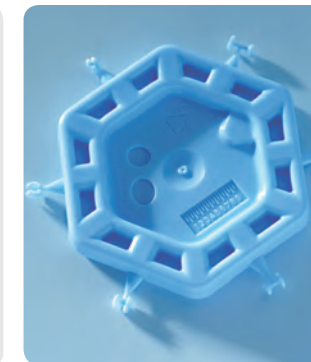

Minimum size of graft: On the back of the Sizer Disk there are recessed templates that indicate the minimum sizes of graft which is placed between the prosthesis head plate and the tympanic membrane. In addition there is a millimeter scale.

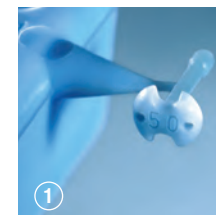

Sizer Total made of plastic: It features recesses and length identification on the top as well as a stem for mounting on the stapes footplate.

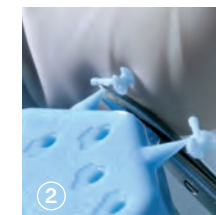

Cutting off the Sizer: With the fine Micro Scissors (REF 8000 172) the Sizer can be removed from the Sizer Disk in the direct vicinity of the stem.

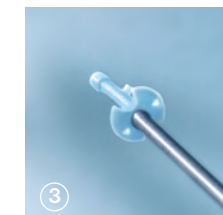

Transport of the Sizer: The Sizer can be transported with a fine aspiration device that sucks the head. Due to the plastic the Sizer is extremely light and therefore easy to handle.



Length determination: Sizer Total is placed on the stapes footplate to intraoperatively determine the optimal length of the titanium prosthesis to be implanted later. By means of adhesion the Sizer remains stable during measurement.

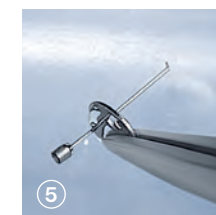

Transport of the TTP-VARIAC: The prosthesis is wetted with a drop of saline solution before removal out of the primary package. You may use the Titanium Tweezers (REF 8000 136) or a fine aspiration device to lift the prosthesis by its head plate.



Length adjustment and fixation of the head plate: The prosthesis along with the head plate is placed in the recess of the Sizer Disk that corresponds to the determined length. With the aid of Micro Closing Forceps (REF 8000 137) the head plate is firmly clamped.



Removal of stem: The projecting stem is removed with Cutting Forceps (REF 8000 171). It can thus be severed easily and with high precision.

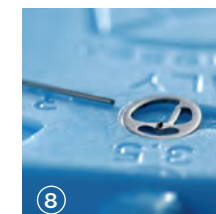

Projecting pin: When the stem has been cut off, a pin remains above the head plate. Its purpose is fixation of the graft, which is placed between the prosthesis head plate and the tympanic membrane.



Finished prosthesis: The finished TTP-VARIAC prosthesis is now ready for implantation.



Important! For full information the Instruction For Use must be read

ACCESSORIES	REF
Titanium Tweezers	8000 136
Titanium Micro Closing Forceps	8000 137
Cutting Forceps, stainless steel	8000 171
Micro Scissors, stainless steel	8000 172
Tray TTP-VARIAC	8000 173

Resterilizable

TTP®-VARIO SYSTEM

Adjustable Length Prostheses

PRECISION LENGTH ADJUSTMENT

TTP-VARIO Titanium Prostheses provide the unique benefits of a length adjustable prosthesis system. The patented clamping mechanism within the head plate securely fixates the head plate to the stem. It provides a flexible design enabling prostheses to be sized as short as 0.75 mm (FL). Precise length adjustments are made with the aid of the TTP-VARIO instrument set (REF 8000 133).

FOR OPTIMIZED INVENTORY LEVELS

The adjustable length system satisfies all lengths within two types of prostheses: one for partial reconstructions and one for total reconstructions. Such flexible use makes a significant contribution to optimizing inventory levels.

CONVINCING BENEFITS

VARIO's elegant design highlights intraoperative visibility and handling. Furthermore, a partially roughened head plate surface causes friction to the smooth cartilage improving contact liability.



TTP-VARIO
Instrument Set
(REF 8000 133)

TTP®-TUEBINGEN TYPE PROSTHESES

LIGHTWEIGHT AND FINELY BALANCED

The TTP-Tuebingen Titanium Prosthesis has a lightweight design which enables the surgeon to adapt the implant to the patient's individual anatomical situation by bending. Furthermore, finely balanced weight distribution ensures secure intraoperative and postoperative fit of the prosthesis.

INTRAOPERATIVE VISIBILITY

An open head plate in conjunction with a slim prosthesis stem further facilitates the handling: As a result the surgeon has maximum intraoperative visibility.

PROVEN IN THE LONG TERM

The TTP-Tuebingen has already been used successfully in tympanoplasty for several decades. As a result, KURZ is not only a hallmark of innovation but also of well-established long-term experience.



TTP-VARIO
BELL Partial Prosthesis
Material:
Pure Titanium (ASTM F67
Medical Grade)
Shaft Diameter: 0.2 mm

ITEM	REF
TTP-VARIO BELL Partial Prosthesis Adjustable Length 1.75 - 4.50 mm (in 0.25 increments) Functional Length (FL) 0.75 - 3.50 mm	1002 010

TTP-VARIO
AERIAL Total Prosthesis
Material:
Pure Titanium (ASTM F67
Medical Grade)
Shaft Diameter: 0.2 mm

ITEM	REF
TTP-VARIO AERIAL Total Prosthesis Adjustable Length 3.0 - 7.0 mm (in 0.25 mm increments)	1004 010

The TTP-VARIO Total Prosthesis is compatible with the OMEGA CONNECTOR (REF 1004 930).

TTP-Tuebingen Type
BELL Partial Prosthesis
Material:
Pure Titanium (ASTM F67
Medical Grade)
Shaft Diameter: 0.2 mm

LENGTH L (mm)	FL (mm)	REF
1.75	0.75	1002 223
2.00	1.00	1002 224
2.25	1.25	1002 225
2.50	1.50	1002 226
2.75	1.75	1002 227
3.00	2.00	1002 228
3.25	2.25	1002 229
3.50	2.50	1002 230

FL: Functional Length

The TTP-Tuebingen Type Total Prosthesis is compatible with the OMEGA CONNECTOR (REF 1004 930).

TTP-Tuebingen Type
AERIAL Total Prosthesis
Material:
Pure Titanium (ASTM F67
Medical Grade)
Shaft Diameter: 0.2 mm

LENGTH L (mm)	REF
3.00	1004 234
3.25	1004 235
3.50	1004 236
3.75	1004 237
4.00	1004 238
4.25	1004 239
4.50	1004 240
4.75	1004 241
5.00	1004 242
5.25	1004 243
5.50	1004 244
6.00	1004 246
6.50	1004 248
7.00	1004 249

DUESSELDORF TYPE PROSTHESES

LONG-TERM EXPERIENCE

With the Duesseldorf Titanium Prosthesis, KURZ demonstrates its well-established long-term experience: This implant has been successfully used for reconstructing the ossicle chain in middle ear reconstruction for over 20 years.

SECURE INTRAOPERATIVE POSITIONING

The features of the implant have set standards for a large number of other generations of prostheses. The cleverly engineered weight distribution of KURZ implants helps the surgeon to achieve secure intraoperative positioning of the prosthesis. The stem of the AERIAL Total Prosthesis and the bell of the BELL Partial Prosthesis have proven reliable throughout the world.

CLINICALLY AND SCIENTIFICALLY EVALUATED

Not only in clinical use are KURZ prostheses evaluated, but the individual benefits are also documented in numerous independent studies and scientific papers.

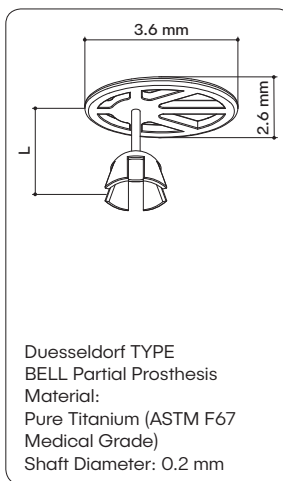
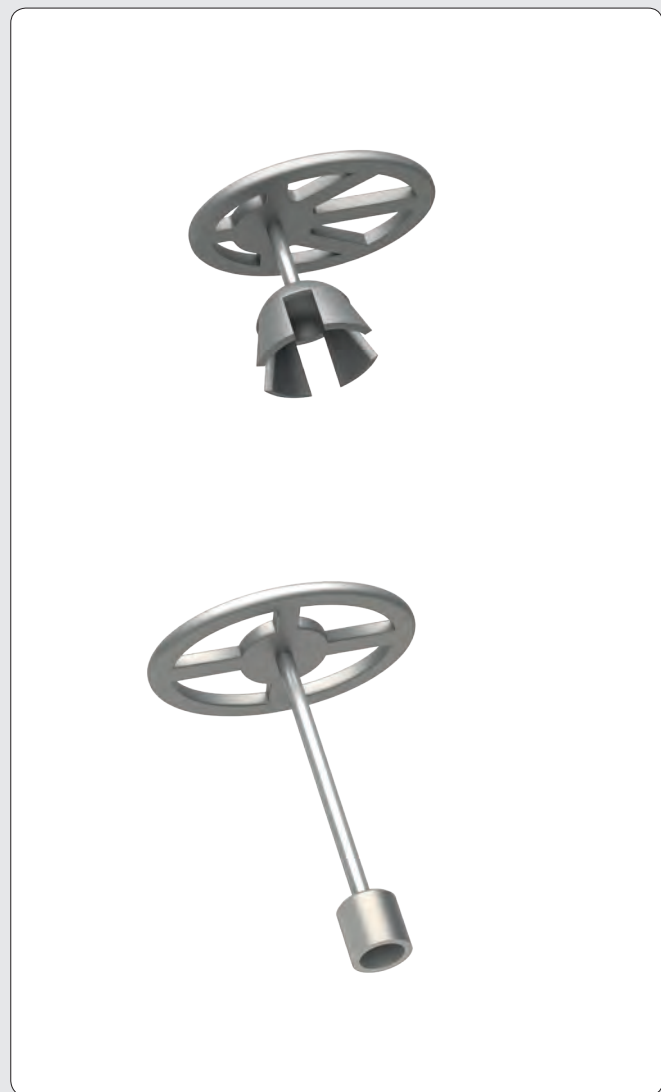

Duesseldorf TYPE
BELL Partial Prosthesis
Material:
Pure Titanium (ASTM F67
Medical Grade)
Shaft Diameter: 0.2 mm

LENGTH L (mm)	FL (mm)	REF
1.75	0.75	1002 023
2.00	1.00	1002 024
2.25	1.25	1002 025
2.50	1.50	1002 026
2.75	1.75	1002 027
3.00	2.00	1002 028
3.25	2.25	1002 029
3.50	2.50	1002 030
4.00	3.00	1002 032
4.50	3.50	1002 033

FL: Functional Length

Special sizes upon request.

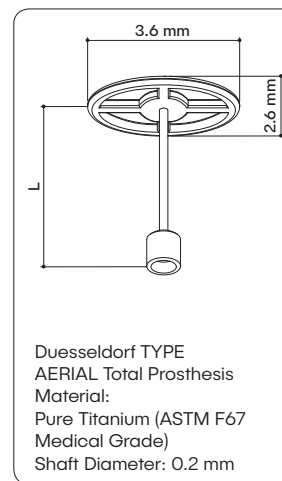

Duesseldorf TYPE
AERIAL Total Prosthesis
Material:
Pure Titanium (ASTM F67
Medical Grade)
Shaft Diameter: 0.2 mm

The Duesseldorf Type AERIAL Total Prosthesis is compatible with the OMEGA CONNECTOR (REF 1004 930).

LENGTH L (mm)	REF
3.00	1004 034
3.25	1004 035
3.50	1004 036
3.75	1004 037
4.00	1004 038
4.25	1004 039
4.50	1004 040
4.75	1004 041
5.00	1004 042
5.25	1004 043
5.50	1004 044
6.00	1004 046
6.50	1004 048
7.00	1004 049

MUNICH^{LMU} TYPE PROSTHESES

CHARACTERISTIC DESIGN

The Munich^{LMU} is a prosthesis with a very characteristic head plate design. It is shaped like an umbrella with an extended rounded edge that creates a wide, atraumatic contact zone to the tympanic membrane. Large fenestrations provide good visual overview during implantation.

STABILITY WHEN COUPLING

Optimal coupling is provided by the particular prosthesis foot: The stem of the AERIAL Total Prosthesis has a cannulated distal footing to increase the fluid adhesion force to the stapes foot plate. The concave surface of the BELL Partial Prosthesis makes direct contact with a broad range of anatomical superstructures.

PROSTHESES IN NUMEROUS LENGTHS

In situ the well-balanced weight distribution provides the prosthesis with the best possible stability and simplified handling. The Munich Style Prosthesis is a fixed length prosthesis family available in 0.25 mm increments.

Developed in close collaboration with the ENT Clinic at LMU Munich University (Germany) Prof. Dr. A. Berghaus, Prof. Dr. J. Müller.



NOT AVAILABLE FOR COMMERCIAL SALE in the U.S. yet.

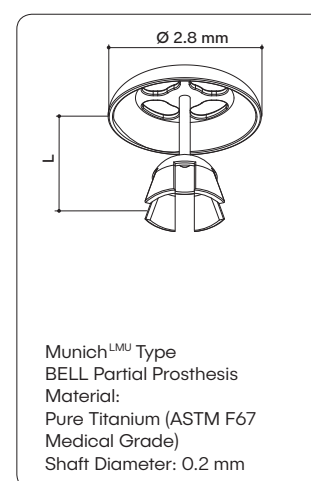

Munich^{LMU} Type
BELL Partial Prosthesis
Material:
Pure Titanium (ASTM F67
Medical Grade)
Shaft Diameter: 0.2 mm

LENGTH L (mm)	FL (mm)	REF
1.75	0.75	1002 073
2.00	1.00	1002 074
2.25	1.25	1002 075
2.50	1.50	1002 076
2.75	1.75	1002 077
3.00	2.00	1002 078
3.25	2.25	1002 079
3.50	2.50	1002 080

FL: Functional Length

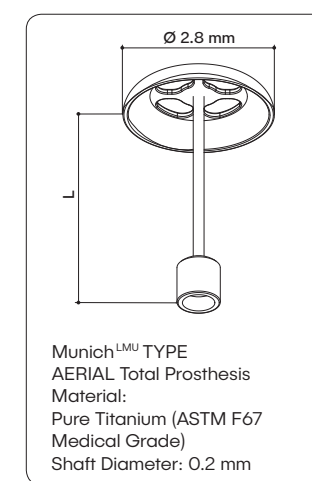

Munich^{LMU} TYPE
AERIAL Total Prosthesis
Material:
Pure Titanium (ASTM F67
Medical Grade)
Shaft Diameter: 0.2 mm

The Munich^{LMU} Type Total Prosthesis is compatible with the OMEGA CONNECTOR (REF 1004 930).

LENGTH L (mm)	REF
3.00	1004 074
3.25	1004 075
3.50	1004 076
3.75	1004 077
4.00	1004 078
4.25	1004 079
4.50	1004 080
4.75	1004 081
5.00	1004 082
5.25	1004 083
5.50	1004 084
6.00	1004 086
6.50	1004 088
7.00	1004 089

MNP MALLEUS NOTCH PROSTHESES

FOR COUPLING TO THE MALLEUS

In ossicle reconstruction the malleus often still exists. Many surgeons want to preserve it and thus ensure stable coupling to the prosthesis.

REDUCED RISK OF DISLOCATION AND MIGRATION

Since the area around the malleus handle usually has the largest tympanic membrane deflection, simultaneous implant/drum contact is beneficial here. MNP's concave recess facilitates this contact when placed under the malleus handle providing implant stability. Because of this recess the head plate of the MNP is relatively smaller.

MAXIMUM INTRAOPERATIVE VISIBILITY

The slimmer profiled, fenestrated head plate increases placement visibility.

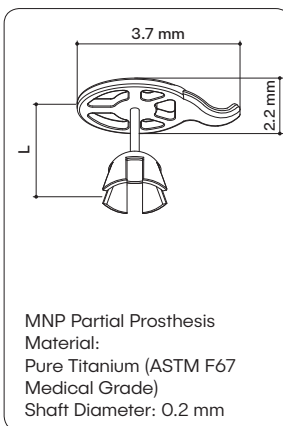

MNP Partial Prosthesis
Material:
Pure Titanium (ASTM F67
Medical Grade)
Shaft Diameter: 0.2 mm

LENGTH L (mm)	FL (mm)	REF
1.75	0.75	1002 423
2.00	1.00	1002 424
2.25	1.25	1002 425
2.50	1.50	1002 426
2.75	1.75	1002 427
3.00	2.00	1002 428
3.25	2.25	1002 429
3.50	2.50	1002 430

FL: Functional Length

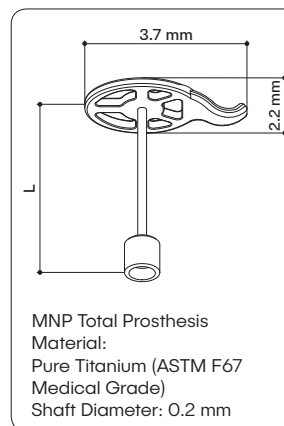

MNP Total Prosthesis
Material:
Pure Titanium (ASTM F67
Medical Grade)
Shaft Diameter: 0.2 mm

The MNP Total Prosthesis is compatible with the OMEGA CONNECTOR (REF 1004 930).

LENGTH L (mm)	REF
3.00	1004 434
3.25	1004 435
3.50	1004 436
3.75	1004 437
4.00	1004 438
4.25	1004 439
4.50	1004 440
4.75	1004 441
5.00	1004 442
5.25	1004 443
5.50	1004 444
6.00	1004 446
6.50	1004 448
7.00	1004 449

MRP MALLEUS REPLACEMENT PROSTHESIS

STABILITY FOR A LONG-LASTING OUTCOME

Postoperative movements of the tympanic membrane can have a negative effect on the optimal position of a middle ear prosthesis. Invasive disease and anteriorly positioned malleus add to the degree of difficulty to reconstruction.

One of the aims of ossicular chain reconstruction is consequently to create a stable reconstruction minimizing the risk of tilting of the prosthesis.

SIMULATES AN ABSENT MANUBRIUM OF MALLEUS

The Malleus Replacement Prosthesis delivers an innovative concept which may considerably improve reconstruction instability of prostheses by creating an accessible lateral platform for implants to couple to. The adjustable Y link can be optimally positioned to the bony rim of the auditory canal.

WIDE RANGE OF APPLICATIONS

The MRP stabilizes and secures a partial or total reconstruction and counteracts dislocation, especially during the initial healing phase. It can be used in conjunction with a large number of KURZ prostheses. Ideally it is suited to interface with the Malleus Notch Prosthesis or the Cavity Bending Pliers (see page 54). The latter can easily be used on various KURZ prosthesis head plates.

Developed in close collaboration with Dr. Robert Vincent, Béziers (Causse Ear Clinic), France.



NOT AVAILABLE FOR COMMERCIAL SALE in the U.S. yet.

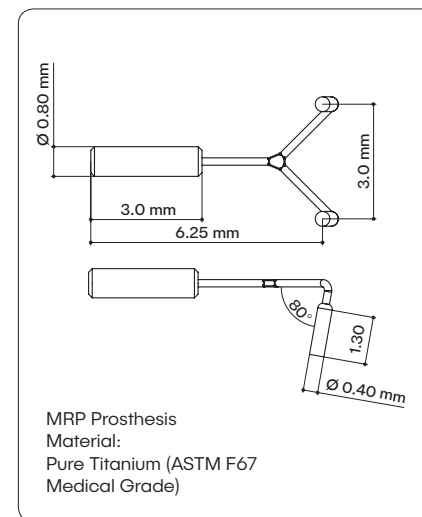

MRP Prosthesis
Material:
Pure Titanium (ASTM F67
Medical Grade)

ITEM	REF
MRP Ø 0.8 x 3.0 mm	1006 960



Ω CONNECTOR

OPTIMIZED FIT

In total ossicular reconstruction, movements of the tympanic membrane can alter the implant position on the stapes footplate. This risk may be reduced by using the OMEGA CONNECTOR together with a total prosthesis. The OMEGA CONNECTOR is designed to compensate for tympanic membrane movements and provide additional stability.

FLEXIBLE JOINT CONNECTION

With sufficient footplate access, the OMEGA CONNECTOR increases the medial surface contact of a total prosthesis. The micro ball joint connects with the cannulated stem of the KURZ total prosthesis. In this way it accommodates drum to headplate angles without prosthesis manipulations.

STABLE CONNECTION

An aspiration tip is ideally used to place the OMEGA CONNECTOR first into the middle ear. The cupped medial end of the total prosthesis is assembled with the OMEGA in situ. A snug and stable fit between the two prostheses makes fixation with adhesive unnecessary. The undersurface of the shoe has a longitudinally milled recess to compensate for footplate irregularity.

Developed in close collaboration with Dr. med. G. Schmid, Reutlingen, Germany.

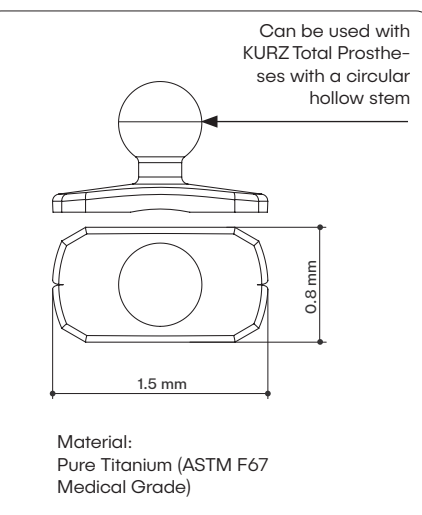
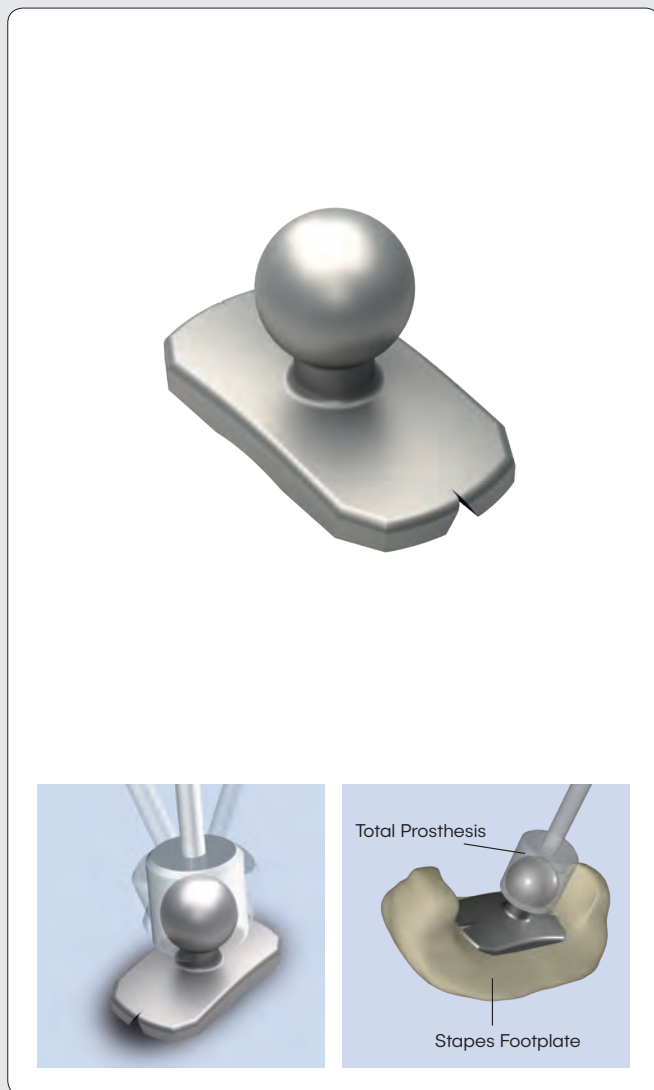

ITEM	FL (mm)	REF
OMEGA CONNECTOR	0.5 mm	1004 930

FL: Functional Length



Additional information



MODULAR SYSTEM FOR KURZ TOTAL PROSTHESES

The OMEGA CONNECTOR is compatible with all KURZ total prostheses that have a hollow stem with a diameter of 0.8 mm at the end of the shaft:

- TTP-VARIAC® System Total
- TTP®-VARIO AERIAL Total
- TTP®-Tuebingen Type AERIAL Total
- Duesseldorf Type AERIAL Total
- MNP Malleus Notch Total Prosthesis
- Munich^{LMU} Type Total Prosthesis

QUICK DETERMINATION OF AVAILABLE SPACE

With the aid of the specially developed OMEGA CONNECTOR Sizer (see page 53) the surgeon can intraoperatively determine whether adequate space prevails for the OMEGA CONNECTOR between the stapes crura remnants. The measuring tip of the OMEGA CONNECTOR Sizer precisely corresponds to the dimensions of the OMEGA CONNECTOR.



Image courtesy of R. Mlynski, Rostock, Germany

ITEM	REF
TTP-VARIAC System Total	1004 020
OMEGA CONNECTOR	1004 930

ITEM	REF
TTP-VARIO AERIAL Total	1004 010
OMEGA CONNECTOR	1004 930

ITEM	REF
Duesseldorf Type AERIAL Total	1004 034 to 1004 049
OMEGA CONNECTOR	1004 930

ITEM	REF
TTP-Tuebingen Type AERIAL Total	1004 234 to 1004 249
OMEGA CONNECTOR	1004 930

ITEM	REF
MNP Malleus Notch Total Prosthesis	1004 434 to 1004 449
OMEGA CONNECTOR	1004 930

ITEM	REF
Munich ^{LMU} Type Total Prosthesis	1004 074 to 1004 089
OMEGA CONNECTOR	1004 930

CLIP® PARTIAL PROSTHESIS DRESDEN TYPE

STANDARDIZED COUPLING FOR MORE SAFETY

The special feature of the CliP Partial Prosthesis Dresden is its spring-loaded fastening mechanism: The CliP standardizes coupling to the stapes head and thus enhances safety for a good postoperative outcome.

SECURE FIT

The elastic CliP ensures a secure fit on the stapes head. Especially in the case of extensive eardrum reconstructions this stability is a major advantage.

EXTREMELY ELEGANT

KURZ implants are designed in such a way that they largely simulate the fine biological structures of the auditory ossicle chain. KURZ addresses this challenge with prosthesis geometries that are extremely fine and push back the limits of feasibility. Their manufacturing process requires the utmost care and precision.

THE ORIGINAL

Over a decade of clinical use including numerous scientific studies confirm the unique benefits of the CliP Partial Prosthesis Dresden – the original among the clip prostheses.

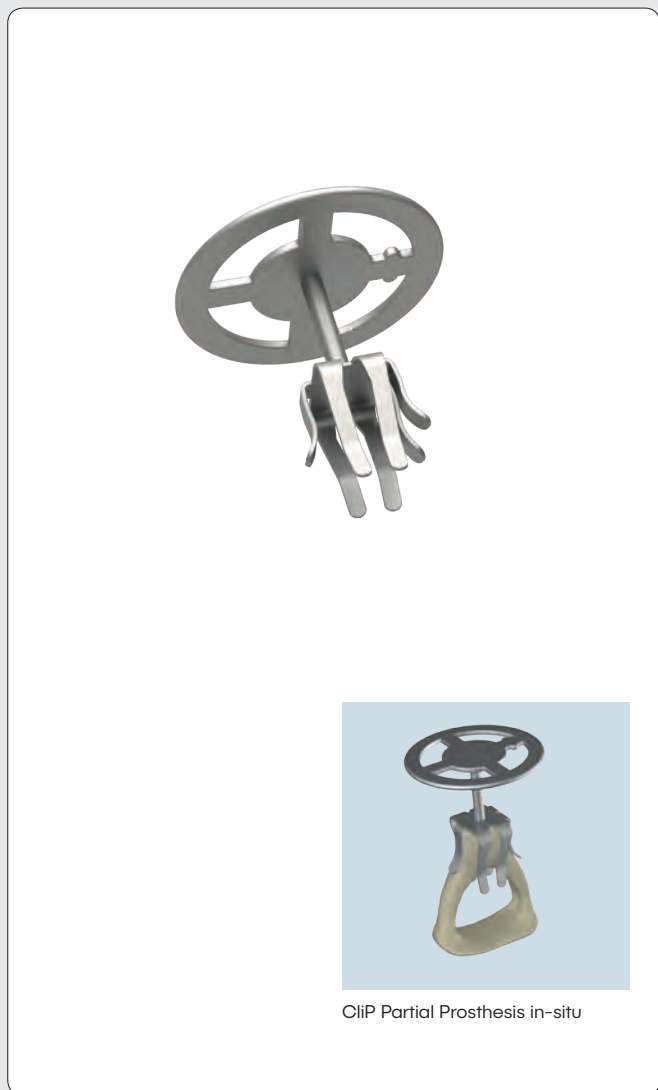

CliP Partial Prosthesis in-situ

CLIP PARTIAL FLEXIBAL® PROSTHESIS

UNDERSTANDING THE FUNCTION

During the healing process, the tympanic membrane migrates to its ultimate position. After reconstruction of the auditory ossicular chain the implant can be susceptible to the environmental changes including dislocation which results in the loss of the incoming acoustical signal across all frequencies.

INTEGRATED MICRO BALL JOINT

A Micro Ball Joint is integrated into the head plate of the FlexiBAL. Consequently, the prosthesis can follow the macro movements of the tympanic membrane and continually align itself managing some of the dislocation effects. In addition, the movable head plate counteracts tension, especially at the annular ligament of the stapes footplate.

STABLE AND CUSTOMIZED

The unique CliP Design provides the prosthesis with stability and standardizes coupling to the stapes head. Both of these benefits ensure an adequate fit of the FlexiBAL. In addition, the integrated Micro Ball Joint allows the surgeon to align the head plate with the tympanic membrane.

Developed in close cooperation with the ENT clinics of the university hospitals in Cologne and Dresden, Germany.

Literature:
Voss, S. E., Nakajima, H. H., Huber, A. M., & Shera, A. C. (2013). Function and Acoustics of the Normal and Diseased Middle Ear. In Puria, S., Fay, R. R., & Popper, A. (Eds). The Middle Ear. Science, Otorhinology, and Technology. Chapter 4. New York, Heidelberg, Dordrecht, London: Springer.

Neudert M., Bornitz M., Lasurashvili N., Schmidt U., Beleites T., Zahnert T.: Impact of Prosthesis Length on Tympanic Membrane's and Annular Ligament's Stiffness and the Resulting Middle Ear Sound Transmission. Otolology & Neurotology: HYPERLINK "http://journals.lww.com/otology-neurotology/toc/2016/10000" October 2016, Volume 37, Issue 9 p e369–e376. Doi: 10.1097/MAO.0000000000001064



Self-retaining on Stapes Capitulum with evaluated CliP Design

Ø 2.6 mm

CliP Partial Prosthesis Dresden
Material:
Pure Titanium (ASTM F67 Medical Grade)
Shaft Diameter: 0.2 mm

LENGTH L (mm)	FL (mm)	REF
1.75	0.75	1002 250
2.00	1.00	1002 251
2.25	1.25	1002 252
2.50	1.50	1002 253
2.75	1.75	1002 254
3.00	2.00	1002 255
3.25	2.25	1002 256
3.50	2.50	1002 257

FL: Functional Length

Special sizes upon request.



Additional information



3.6 mm

2.6 mm

CliP Partial FlexiBAL
Material:
Pure Titanium (ASTM F67 Medical Grade)
Shaft Diameter: 0.2 mm

LENGTH L (mm)	FL (mm)	REF
1.75	0.75	1002 350
2.00	1.00	1002 351
2.25	1.25	1002 352
2.50	1.50	1002 353
2.75	1.75	1002 354
3.00	2.00	1002 355
3.25	2.25	1002 356
3.50	2.50	1002 357

FL: Functional Length

Special sizes upon request.



Additional information



ANGULAR CLIP® PROSTHESIS

ANGULAR PROSTHESIS PLESTER

REGENSBURG TYPE TOTAL PROSTHESIS

PRESERVING THE ORIGINAL STRUCTURES

One of the challenges of middle ear surgery is to preserve as much of the original structures as possible. When recommunicating the incus and stapes from discontinuity, preserving the native ossicles from progressive atrophy in a neutral position are important design configurations. The Angular CliP bridges the incudostapedial joint with the aid of two mechanisms.

CLIPPING AND CRIMPING

Standardized coupling to the stapes head is provided by the CliP. Its spring loaded foils produce a secure atraumatic fit while two titanium bands are crimped to the remaining incus long process.

SOLID TITANIUM BRIDGE

This type of reconstruction creates a bridge for the incoming acoustic signal. Its design pays particular attention to ligamental stress with its neutral fit.

Cartilage may be draped on the prosthesis laterally to protect the tympanic membrane

Developed in close collaboration with Prof. Dr. med. K. B. Hüttenbrink, University of Cologne, Germany.

STANDARDIZED CONNECTION

Like the Angular CliP the Angular Plester Prosthesis creates a secure, standardized connection between the stapes head and the long process of the incus when discontinuity is present. The Plester features a bell that is placed on the superstructure and two titanium bands which are crimped to the remnant incus.

GOOD TOLERANCE IN LONG-TERM USE

The Angular Prosthesis is made of pure titanium which demonstrates excellent tolerance long-term. In addition, the mechanical coupling has proven to be relatively stable.

EVEN IF THE INCUS IS CONSIDERABLY SHORTENED

Even if the distal end of the incus is considerably eroded, the Angular Prosthesis is a reliable, neutrally placed solution. Cartilage may be draped laterally on the prosthesis to protect the tympanic membrane.

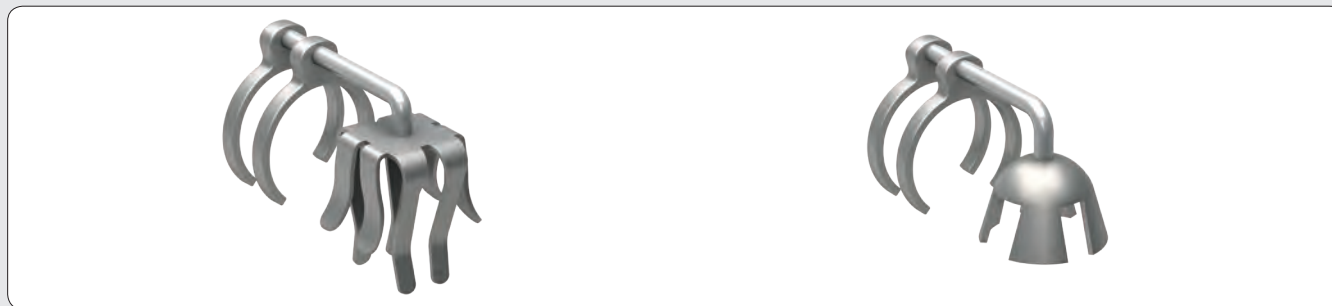

Angular CliP Prosthesis
Material:
Pure Titanium (ASTM F67
Medical Grade)
Shaft Diameter: 0.2 mm

LENGTH L (mm)	REF
2.25	1002 615
3.25	1002 617

Angular Prosthesis Plester
Material:
Pure Titanium (ASTM F67
Medical Grade)
Shaft Diameter: 0.2 mm

LENGTH L (mm)	REF
2.25	1002 610
3.25	1002 612

OVAL STEM FOR LARGER AREA OF CONTACT

An enlarged oval stem end is the trademark of the Regensburg Type Total Prosthesis. It increases the area of contact with the stapes footplate, and together with a lower center of gravity ensures good balance and facilitates intraoperative handling.

ADVANTAGEOUS FEATURES

Small recesses in the head plate indicate the position of the stem. Below the head plate the shaft has a diameter of only 0.2 mm. Consequently, it can be easily articulated to match the tympanic membrane angle.

Developed in close collaboration with Regensburg University ENT Clinic, Germany and its middle ear research laboratory.



Regensburg Type
Total Prosthesis
Material:
Pure Titanium (ASTM F67
Medical Grade)
Shaft Diameter: 0.2 mm

LENGTH L (mm)	REF
4.00	1004 458
4.25	1004 459
4.50	1004 460
4.75	1004 461
5.00	1004 462



Additional information

STAPEDIOPLASTY PROSTHESES



PORTFOLIO OF OPTIONS

One critical step in stapedioplasty is the coupling of the prosthesis to the long process of the incus. KURZ meets this requirement with solutions for various needs and schools.

CRIMPING – EXTREMELY GENTLE MODELING

Wide, perforated or exceptionally elegant loops in KURZ Crimp Prostheses facilitate modeling around the long process of the incus. This gentle but stable coupling supports good transmission of the incoming acoustical signal as well as protects the sensitive mucosa.

CLIPPING – SUPERELASTIC BANDS

A standardized form of coupling is provided by KURZ Clip Prostheses. Initial practical experience has shown that the superelastic nitinol band of the NiTiFLEX reduces the application force required when placed on to the incus. The contact-free zones are also designed to ensure that vascular nutrition of the surrounding structures is undisturbed.

HEATING – SHAPE MEMORY EFFECT

KURZ only uses pure titanium or titanium-nitinol combinations. Nitinol can have various characteristics: In addition to the superelastic properties, KURZ also uses the more traditional shape memory version of nitinol in their NiTiBOND prosthesis. When heated with the aid of a laser, the NiTiBOND loop closes in its pre-defined shape. The result is a more atraumatic, standardized coupling.

BUCKETS – EXTRA DEEP WELL

KURZ Bucket Prostheses have extra deep wells to ensure more consistent coupling with the lenticular process. The elbow on the bail wire provides additional safety in intraoperative handling. The KURZ Bucket Prosthesis is constructed of pure titanium which is an extremely lightweight material, as well as having proven biocompatibility and MRI conditionality.

OPTIMAL SOLUTIONS FOR REVISION SURGERY

KURZ also offers solutions for revision surgery. The MVP with its micro ball joint and extra long malleus Clip creates a direct, adaptable and standardized connection between the malleus and stapes footplate. The Angular Piston stabilizes coupling between a shortened incus and the inner ear when bone resorption has occurred.

MRI SAFETY

MRI safety tests for future potential Tesla levels (e.g. 7.0 T) are performed on the KURZ prostheses, making them long-term implants.

To protect the surrounding tissue and prevent the risk of adhesions, the stem of KURZ Stapes Prostheses are rounded. In addition, all KURZ implants are available in standard sizes making shortening redundant.

CRIMPING



Matrix Stapes Prosthesis



K-Piston Stapes Prosthesis



Skarzynski Piston Stapes Prosthesis



Angular Piston Stapes Prosthesis

CLIPPING



NiTiFLEX Stapes Prosthesis



Soft Clip Stapes Prosthesis



Clip Piston dWengen Stapes Prosthesis



Clip Piston MVP Stapes Prosthesis

BUCKETS



Bucket Type Stapes Prosthesis

HEATING



NiTiBOND Stapes Prosthesis

MATRIX STAPES PROSTHESIS

HIGHLY COMPLEX STRUCTURES

The latest studies* concerning the incus show that especially the cross-section, geometry, and size of the auditory ossicle can vary enormously from person to person and be highly complex. KURZ has addressed this challenge by developing stapes prostheses with a perforated loop band.

EASIER MODELING

Longitudinal perforations in the band ensure that the loop is extremely malleable and easy to model around the long process of the incus. Consequently, the coupling is simplified significantly and more uniform. The additional material surface of the MatriX band provides greater stability during the crimping process.

MINIMAL LOSS OF SOUND CONDUCTION

From an acoustomechanical viewpoint there should be as little play as possible in the coupling area between the prosthesis and the incus. A more consistent crimp along with increased surface area helps to ensure that the incoming acoustic signal is conducted to the inner ear with minimal loss. To counteract a potential necrosis risk to the sensitive mucosa the coupling should not be too firm either.

Developed in close collaboration with Jack Kartush, MD, Michigan Ear Institute, Bloomfield, MI, USA.

*Tóth, M., Moser, G., Rösch, S., Grabmair, G., & Rasp, G. (2013). Anatomic Parameters of the Long Process of Incus for Stapes Surgery. *Otology & Neurotology*, 34(9):1564-1570.

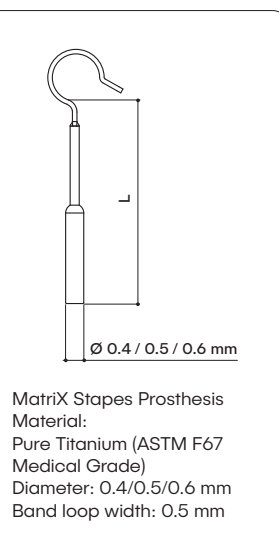

LENGTH L (mm) Ø 0.4 mm	REF	LENGTH L (mm) Ø 0.5 mm	REF	LENGTH L (mm) Ø 0.6 mm	REF
3.50	1006 003	3.50	1006 023	3.50	1006 043
3.75	1006 004	3.75	1006 024	3.75	1006 044
4.00	1006 005	4.00	1006 025	4.00	1006 045
4.25	1006 006	4.25	1006 026	4.25	1006 046
4.50	1006 007	4.50	1006 027	4.50	1006 047
4.75	1006 008	4.75	1006 028	4.75	1006 048
5.00	1006 009	5.00	1006 029	5.00	1006 049
5.25	1006 010	5.25	1006 030	5.25	1006 050
5.50	1006 011	5.50	1006 031	5.50	1006 051

K-PISTON STAPES PROSTHESIS

USED MOST OFTEN WORLDWIDE

One of the most commonly used KURZ Stapes Prosthesis in the world is the K-Piston. Its tested design has set standards for the development of many other generations of stapes prostheses. Numerous scientific studies support, inter alia, the excellent long-term suitability of this prosthesis.

REDUCED NECROSIS RISK

The wide band of the K-Piston, which, due to elaborate processes, is soft and flexible, helps to reduce the risk of necrosis. The loop is spiral-shaped as well preventing the loop tip and the loop attachment to touch during crimping. Consequently, the K-Piston is also suitable for small incus diameters. In addition, a low material pretension in the titanium loop ensures a dimensional firmness after crimping.

ATRAUMATIC DESIGN

The K-Piston made of pure titanium with its atraumatic rounded piston end is available in fixed lengths and diameters. The segment between the piston and the loop area is smooth and round minimizing an attachment surface for vibration-damping scar formation.

Developed in close collaboration with the ENT Clinic of Essen University, Germany.

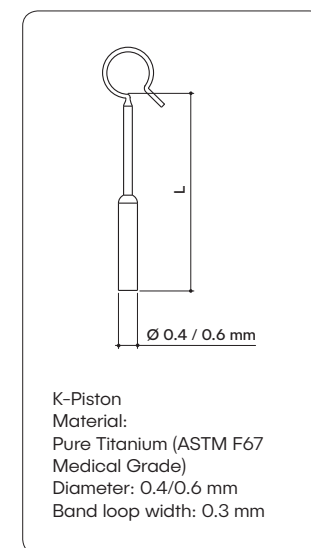

LENGTH L (mm) Ø 0.4 mm	REF	LENGTH L (mm) Ø 0.6 mm	REF
3.50	1006 103	3.50	1006 153
3.75	1006 104	3.75	1006 154
4.00	1006 105	4.00	1006 155
4.25	1006 106	4.25	1006 156
4.50	1006 107	4.50	1006 157
4.75	1006 108	4.75	1006 158
5.00	1006 109	5.00	1006 159
5.25	1006 110	5.25	1006 160
5.50	1006 111	5.50	1006 161
6.00	1006 112	6.00	1006 162
7.00	1006 114	7.00	1006 164
8.00	1006 116	8.00	1006 166
9.00	1006 118	9.00	1006 168
10.00	1006 120	10.00	1006 170

SKARZYNSKI PISTON STAPES PROSTHESIS

LIGHTWEIGHT AND SLENDER

The Skarzynski Piston is an extremely lightweight and slender prosthesis. It allows the surgeon to have a clear intraoperative overview and is particularly suitable in situations with a narrow oval niche.

INDIVIDUAL AND PRECISE COUPLING

The narrow offset band facilitates an easy manual crimp. The offset loop fits around the incus without its end meeting the loop attachment of the prosthesis, thereby enabling customized, precise coupling.

FOR NUMEROUS ANATOMICAL CHALLENGES

KURZ has developed and improved the Skarzynski Piston on the basis of traditional crimp prostheses. As a result, the Skarzynski Piston is suited to meet the numerous anatomical challenges.

Developed in close collaboration with Prof. Dr. Skarzynski, Poland.



ANGULAR PISTON STAPES PROSTHESIS

SECURE COUPLING IN SPITE OF EROSION

In otosclerotic cases with advanced erosion of the long process of the incus, coupling of a conventional stapes prosthesis is often not possible. This can be observed in particular in connection with revision surgery, after stapedectomy or stapedotomy.

TWO TITANIUM BANDS AS CLAMP

In such cases, the Angular Piston provides a simple form of coupling: Its two titanium bands are crimped around the shortened process of the incus, fixing the implant in place while the shaft of the prosthesis is inserted into the vestibule in the customary way.

TRIED AND TESTED IN ALL FREQUENCY RANGES

The Angular Piston provides excellent sound transmission due to its design and the material properties of titanium. Low mass and high rigidity are particularly beneficial also in the high frequencies.

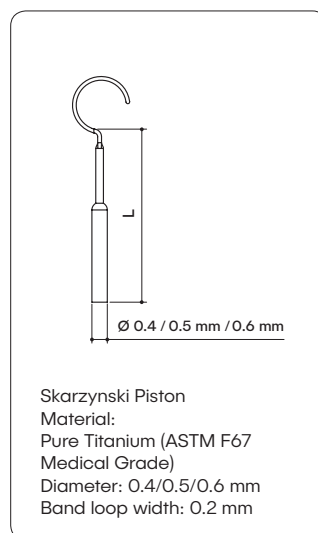

Skarzynski Piston
Material:
Pure Titanium (ASTM F67
Medical Grade)
Diameter: 0.4/0.5/0.6 mm
Band loop width: 0.2 mm

LENGTH L (mm) Ø 0.4 mm	REF	LENGTH L (mm) Ø 0.5 mm	REF	LENGTH L (mm) Ø 0.6 mm	REF
3.50	1006 053	3.50	1006 063	3.50	1006 073
3.75	1006 054	3.75	1006 064	3.75	1006 074
4.00	1006 055	4.00	1006 065	4.00	1006 075
4.25	1006 056	4.25	1006 066	4.25	1006 076
4.50	1006 057	4.50	1006 067	4.50	1006 077
4.75	1006 058	4.75	1006 068	4.75	1006 078
5.00	1006 059	5.00	1006 069	5.00	1006 079
5.50	1006 061	5.50	1006 071	5.50	1006 081

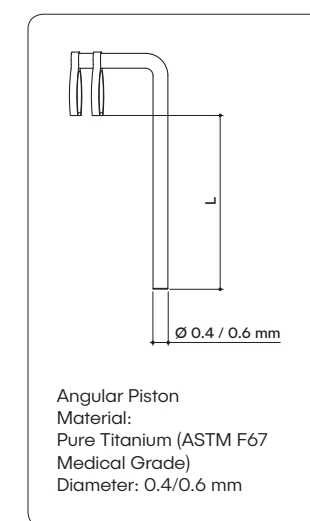

Angular Piston
Material:
Pure Titanium (ASTM F67
Medical Grade)
Diameter: 0.4/0.6 mm

LENGTH L (mm) Ø 0.4 mm	REF	LENGTH L (mm) Ø 0.6 mm	REF
4.25	1006 600	4.25	1006 650
4.50	1006 601	4.50	1006 651
4.75	1006 602	4.75	1006 652



Additional information



NITIFLEX STAPES PROSTHESIS

EVOLUTION OF THE CLIP STAPES PROSTHESIS

One important milestone in the evolution of stapes prosthesis is the development of the NiTiFLEX. Its proven CliP technology standardizes coupling of the prosthesis to the long process of the incus increasing the likelihood of a good postoperative outcome.

SUPERELASTIC NITINOL

As opposed to conventional CliP prostheses, the NiTiFLEX has a loop made of superelastic nitinol which considerably reduces the attachment force. Extensive simulation and test series during the development process aimed to further enhance the transmission properties of the prosthesis.

REDUCED PRESSURE TOWARD INNER EAR

The prosthesis does not completely surround the incus. Laterally and medially there are prosthetic contact zones for a reliable acoustic sound transmission in the direction of force F_{Sound} . The attachment direction minimizes the risk of adding pressure in the direction of the inner ear. In addition, contact-free zones ensure continuous vascular nutrition of the mucosa. A wide, flat CliP band minimizes pressure peaks and may reduce the risk of necrosis.

The NiTiFLEX is available in all standard lengths.

Easy insertion with the aid of the Soft CliP Hook (REF 8000 127).

Developed in close collaboration with Tuebingen University ENT Clinic and the Institute of Engineering and Computational Mechanics at the University of Stuttgart (ITM), Germany.



SOFT CLIP® STAPES PROSTHESIS

STANDARDIZED COUPLING WITHOUT CRIMPING

KURZ CliP Prostheses for stapedioplasty provide standardized coupling to the long process of the incus without crimping. The flexible band clip gently attaches with minimal application force. Its spring type mechanism conforms to multitude incus variations ensuring standardized and secure coupling.

CONTINUOUS BLOOD SUPPLY TO THE MUCOSA

The Soft CliP is made of pure, high quality titanium. This material possesses impressive long-term biocompatibility benefits. The wide band distributes surface tension to reduce risk of pressure necrosis. Contact free zones also prevent strangulation of the mucosa and contribute to continuous vascular supply. The contact zones run laterally and medially in the direction of the acoustic signal (F_{Sound}) to optimize the acoustic transmission.

SOFT CLIP HOOK FOR EASY INSERTION

A specially designed Soft CliP Hook (see page 57) helps the surgeon to attach the prosthesis onto the incus with reduced force. As a result, movement toward the inner ear is also reduced.

Developed in close collaboration with Dr. med. Schimanski, Luene, and Dr. Ing. Eiber, ITM, Stuttgart, Germany.

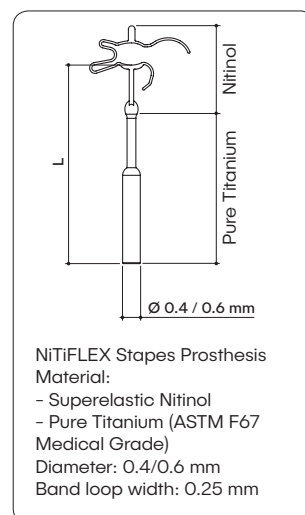

LENGTH L (mm) Ø 0.4 mm	REF	LENGTH L (mm) Ø 0.6 mm	REF
3.50	1007 203	3.50	1007 253
3.75	1007 204	3.75	1007 254
4.00	1007 205	4.00	1007 255
4.25	1007 206	4.25	1007 256
4.50	1007 207	4.50	1007 257
4.75	1007 208	4.75	1007 258
5.00	1007 209	5.00	1007 259
5.50	1007 211	5.50	1007 261

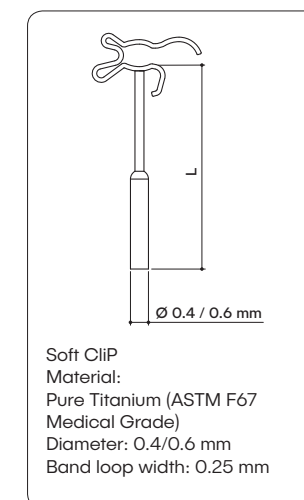

LENGTH L (mm) Ø 0.4 mm	REF	LENGTH L (mm) Ø 0.6 mm	REF
3.50	1006 203	3.50	1006 253
3.75	1006 204	3.75	1006 254
4.00	1006 205	4.00	1006 255
4.25	1006 206	4.25	1006 256
4.50	1006 207	4.50	1006 257
4.75	1006 208	4.75	1006 258
5.00	1006 209	5.00	1006 259
5.50	1006 211	5.50	1006 261



Additional information



Additional information



CLIP® PISTON àWENGEN STAPES PROSTHESIS

CLIP® PISTON MVP STAPES PROSTHESIS FOR MALLEOVESTIBULOPEXY

PIONEER AMONG THE CLIP STAPES PROSTHESES

As the classic model incorporating CliP technology for stapes prostheses, the CliP Piston àWengen standardizes the insertion procedure: Exerting slight pressure the CliP is attached to the long process of the incus. Medial movements toward the inner ear are avoided.

STABLE ACOUSTIC SIGNAL TRANSMISSION

The prosthesis is laterally and medially coupled according to the acoustic signal direction, resulting in an optimized signal transmission. Contact free zones preserve vascular supply and reduce inadvertent point necrosis.

GOOD ACOUSTIC TRANSMISSION THANKS TO PURE TITANIUM

Even at high frequencies, titanium is an advantageous prosthetic material due to its low mass, exceptional acoustic transmission properties and biocompatibility.



CLIP TECHNOLOGY PROVEN IN THE LONG TERM

The CliP Piston MVP is designed for malleus to footplate revision stapes surgery. Long term usage show that the CliP easily standardizes consistent coupling to the neck of the malleus.

BALL JOINT PROSTHESIS FOR MALLEOVESTIBULOPEXY

The extra long dimensions with an integrated ball joint simplify the complicated off axis positioning of traditional malleus to footplate implants. The ball joint additionally allows for the piston to be centered in the fenestration reducing tangential friction.

POSTOPERATIVE STABILITY

After adaptation of the implant the ball joint remains stable. The risk of postoperative dislocation is accordingly reduced.

Developed in close collaboration with Prof. Dr. Häusler, Bern University Canton Hospital, Switzerland.

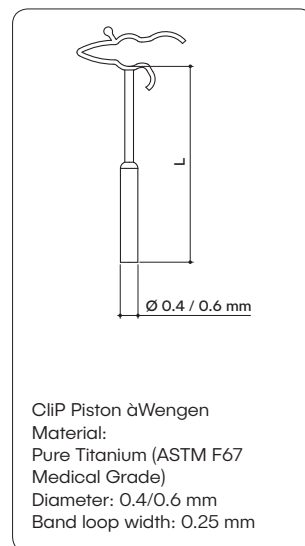
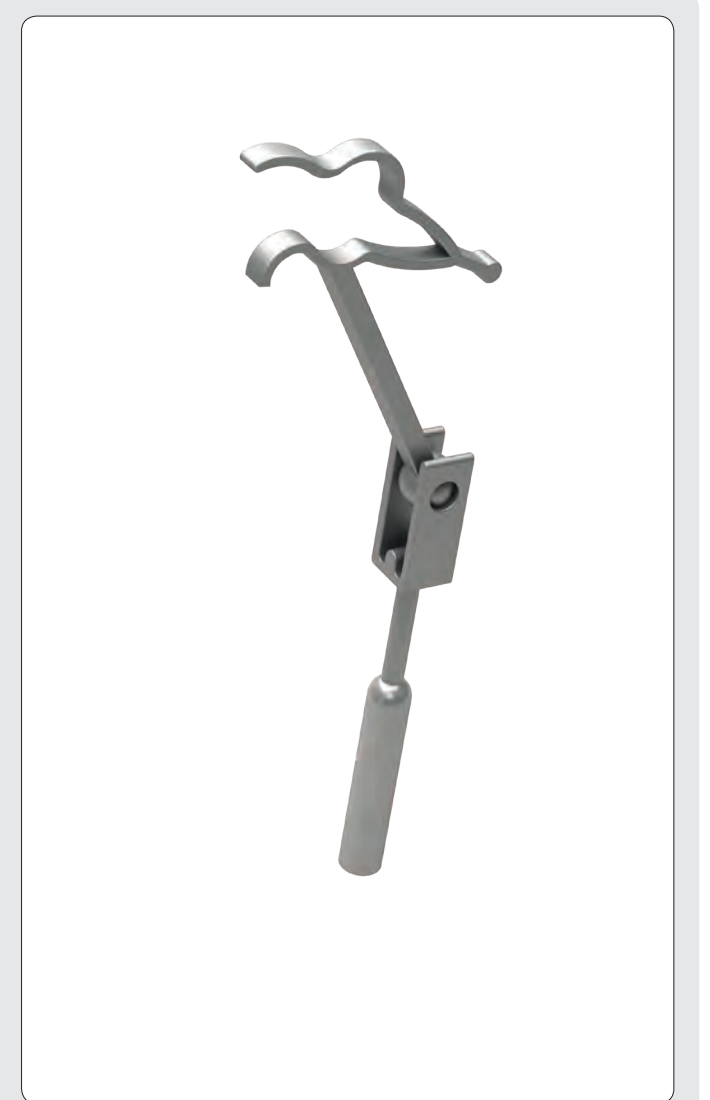

CliP Piston àWengen
Material:
Pure Titanium (ASTM F67
Medical Grade)
Diameter: 0.4/0.6 mm
Band loop width: 0.25 mm

LENGTH L (mm) Ø 0.4 mm	REF	LENGTH L (mm) Ø 0.6 mm	REF
3.50	1006 803	3.50	1006 853
3.75	1006 804	3.75	1006 854
4.00	1006 805	4.00	1006 855
4.25	1006 806	4.25	1006 856
4.50	1006 807	4.50	1006 857
4.75	1006 808	4.75	1006 858
5.00	1006 809	5.00	1006 859
5.50	1006 811	5.50	1006 861

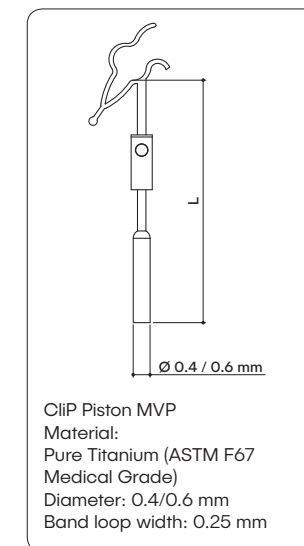

CliP Piston MVP
Material:
Pure Titanium (ASTM F67
Medical Grade)
Diameter: 0.4/0.6 mm
Band loop width: 0.25 mm

LENGTH L (mm) Ø 0.4 mm	REF	LENGTH L (mm) Ø 0.6 mm	REF
5.00	1006 708	5.00	1006 758
5.25	1006 709	5.25	1006 759
5.50	1006 710	5.50	1006 760
5.75	1006 711	5.75	1006 761
6.00	1006 712	6.00	1006 762
6.25	1006 713	6.25	1006 763
6.50	1006 714	6.50	1006 764



BUCKET TYPE STAPES PROSTHESIS

COMPLETES THE PORTFOLIO OF COUPLING OPTIONS

With the characteristic Bucket Type Stapes Prosthesis, KURZ rounds off its stapes portfolio offering four separate coupling mechanisms to stapes surgery.

GENTLE AND SECURE

The KURZ bucket has a comparatively deep well in two diameters to manage the variety of lenticles. It facilitates surface contact on the medial side of the incus. A bail wire is configured for better management in events of dislocation.

EXCELLENT SOUND TRANSMISSION PROPERTIES

Due to its material, pure titanium, the Bucket Type Stapes Prosthesis combines the advantages of excellent biocompatibility with reduced weight. As a result, the prosthesis features excellent sound transmission properties.

Developed in close collaboration with Joseph Roberson MD, Palo Alto, USA.

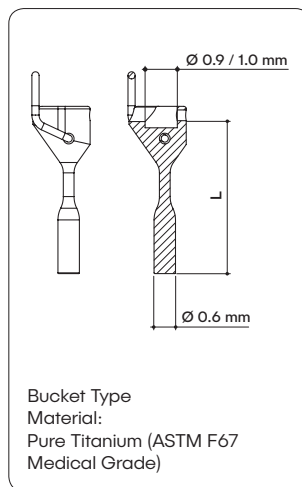

LENGTH L (mm)	REF
INNER DIAMETER (ID) 0.9 mm	
4.00	1006 543
4.25	1006 544
4.50	1006 545

LENGTH L (mm)	REF
INNER DIAMETER (ID) 1.0 mm	
4.00	1006 563
4.25	1006 564
4.50	1006 565

NITIBOND® STAPES PROSTHESIS

CRIMP-FREE COUPLING

The NiTiBOND Stapes Prosthesis combines the proven properties of CiIP Stapes Prostheses with the benefits of shape memory nitinol. The result is an optimized mucosal sparing custom coupling.

FOR ALL INCUS SIZES

Extensive experience in the development of stapes prostheses, connected with sound knowledge of the middle ear, created the basis for the geometry of the unique nitinol loop: Due to its design it is suitable for almost all incus sizes.

The nitinol loop has four integrated contact zones that interface with the surface of the mucosa, conforming to the asymmetrical dimensions of the incus. Additionally, the loop also features three independent activation zones which keep thermal transfer from the mucosa surface during laser activation. These activation zones can be sequentially closed producing a custom coupling to the individualized incus.

The elasticity of the respective zones ensures that pressure is applied as uniformly as possible. A flat wide band reduces the risk of pressure points. To complement the nitinol loop the prosthesis stem is made of pure titanium.

REDUCED RISK IN LASER SETUP

The laser settings are determined outside the middle ear with the aid of the Thermo-Dummy. The dummy is delivered together with the NiTiBOND in the KURZ triangular box.

Developed in close collaboration with the ORL Clinic of the University Hospital Zuerich and the Institute of Engineering and Computational Mechanics at the University of Stuttgart, Germany.



KURZ triangular box:
The NiTiBOND Stapes Prosthesis and the Thermo-Dummy are delivered in the KURZ triangular box.



Thermo-Dummy: With a fine instrument (hook) the Thermo-Dummy is lifted out of its anchorage and moved into a vertical position.



Application of the laser: To determine the correct settings the surgical laser is tested on the Thermo-Dummy and adjusted accordingly.



Secure closure of the NiTiBOND:
After setting the laser it can be used for closing the NiTiBOND securely.

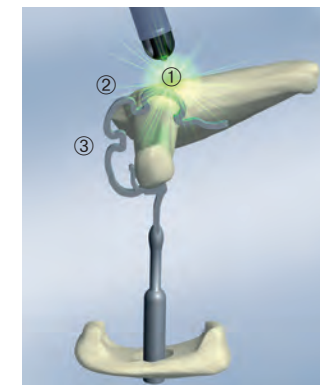

1. ThermoActive zone:
First step, the first ThermoActive zone of the prosthesis loop must be engaged by the evaluated settings for the laser.

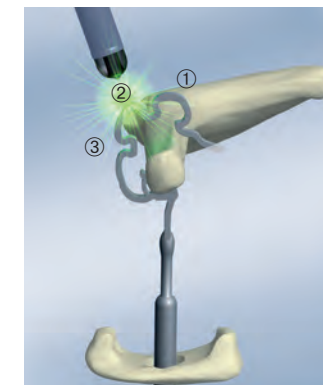

2. ThermoActive zone:
The second shot to the ThermoActive zone in the center position.

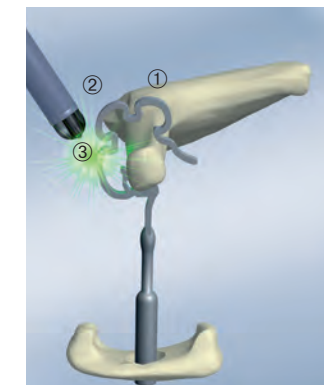

3. ThermoActive zone:
The nitinol loop closes with a laser shot at the third ThermoActive zone.

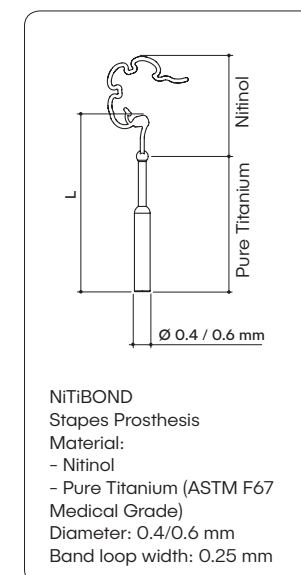
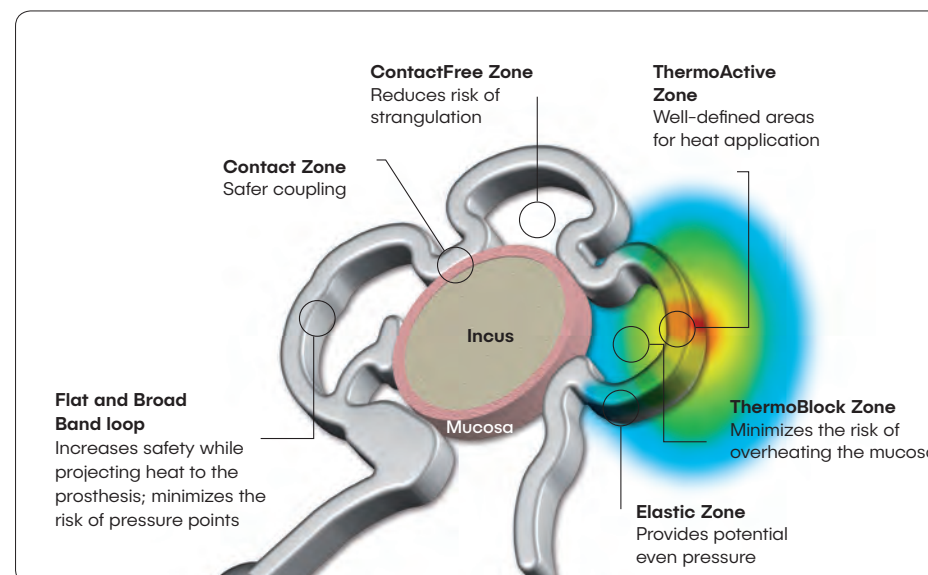

LENGTH L (mm)	REF
Ø 0.4 mm	
3.50	1007 103
3.75	1007 104
4.00	1007 105
4.25	1007 106
4.50	1007 107
4.75	1007 108
5.00	1007 109
5.50	1007 111

LENGTH L (mm)	REF
Ø 0.6 mm	
3.50	1007 153
3.75	1007 154
4.00	1007 155
4.25	1007 156
4.50	1007 157
4.75	1007 158
5.00	1007 159
5.50	1007 161



Additional information

VENTILATION TUBES: ESTABLISHED DESIGNS FOR SHORT- AND LONG-TERM VENTILATION



KURZ Ventilation Tubes are excellent solutions for aeration of the middle ear. A complement of geometrical designs has been created for short, mid and long term ventilation. Focus on biocompatible materials provide excellent tissue tolerance.

LARGE INNER LUMEN

Easy secretion discharge and optimal ventilation are ensured by comparatively larger inner lumens while maintaining dimensionally smaller overall tubes.

Tube lengths between flanges and smooth surfaces are also a key design feature which more efficiently facilitate suction and drainage.

FUNCTIONAL FEATURES

Unique to KURZ, the Tuebingen Type Tube features medial eyelet flanges and therefore is ideally suited for longer term ventilation. The Beveled Type Tube is more notably suited for narrow canals.

Ventilation tubes that can be inserted without prior paracentesis simplify handling: The trocar on which the matching Trocar Ventilation Tube is mounted perforates the tympanic membrane, inserting the ventilation tube. The Minimal Type Ventilation Tube has an integrated trocar such that the tube is placed simultaneously with the paracentesis.



TUEBINGEN TYPE VENTILATION TUBES

THE CLASSIC DESIGN

Tuebingen Tubes are classic "collar button" ventilation tubes for aeration of the middle ear. KURZ manufactures this design in gold-platinum, gilded silver, and pure titanium. Titanium has excellent tissue tolerance.

COMPARATIVELY LARGE INNER DIAMETER

A particularly smooth surface and large inner lumen facilitates secretion discharge and drainage while the outer diameter is comparatively small. This tube comes in three different diameters providing flexibility in ventilation time, suction access and canal dimension without changing insertion technique.

OPTIMAL FIT DUE TO SHORT LENGTH

The Tuebingen tube has a relatively short length which, combined with wide flanges, ensures a more consistent fit into the tympanostomy. If required, a tube with retention wire can make the insertion easier.



BEVELED TYPE VENTILATION TUBES

VERY SMALL SIZES

This Beveled Ventilation Tube comes in three progressive sizes designed to overcome smaller canals to effusion volume challenges. The paediatric version (size 0) has a 0.75 mm inner diameter and a length of 0.70 mm ideally suited for a narrow outer ear canal.

EASY TO INSERT

The ventilation tube is made of a gold-platinum composition. Its funnel shaped outer flange facilitates insertion and suction of pervasive effusion.

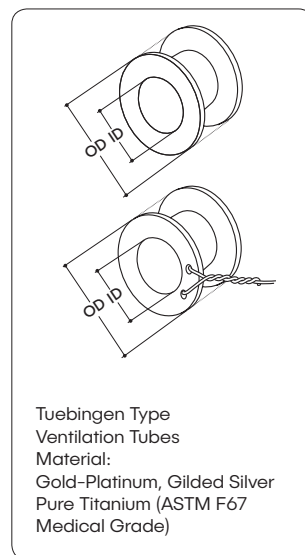
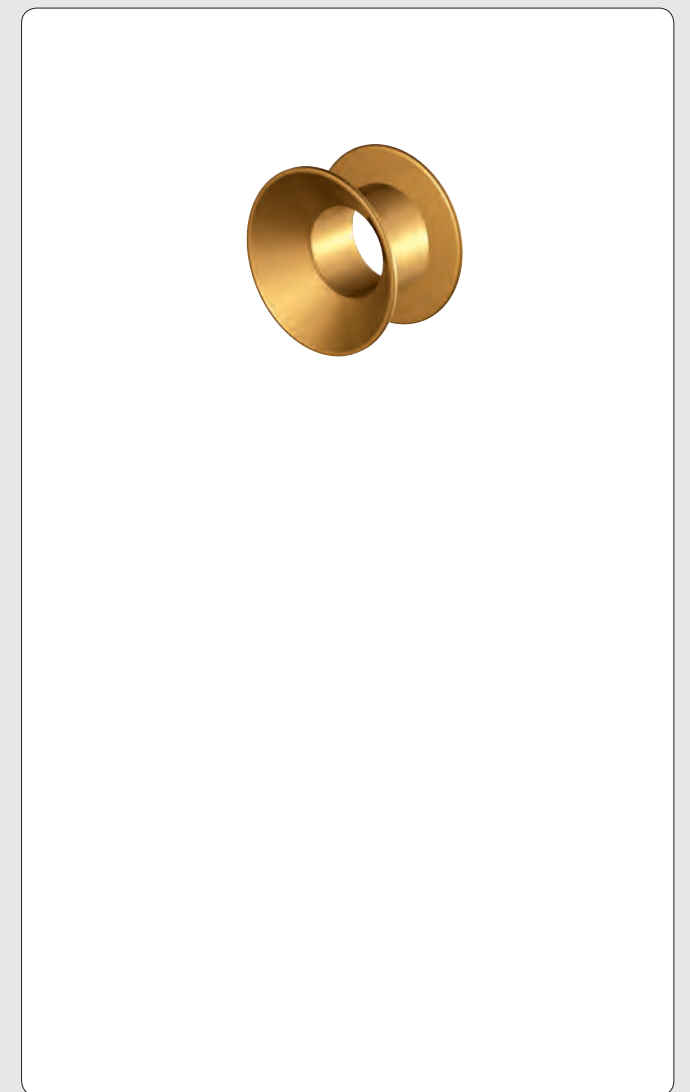

Tuebingen Type Ventilation Tubes
Material:
Gold-Platinum, Gilded Silver
Pure Titanium (ASTM F67 Medical Grade)

MATERIAL: GOLD-PLATINUM	ID mm	OD mm	LENGTH mm	REF
Size 1	1.25	2.55	1.60	1015 001
Size 1 with wire Not MRI conditional	1.25	2.55	1.60	1015 002
Size 2	1.50	2.80	1.60	1015 003
Size 2 with wire Not MRI conditional	1.50	2.80	1.60	1015 004
MATERIAL: GILDED SILVER	ID mm	OD mm	LENGTH mm	REF
Size 1	1.25	2.55	1.60	1015 010
Size 1 with wire Not MRI conditional	1.25	2.55	1.60	1015 011
Size 2	1.50	2.80	1.60	1015 012
Size 2 with wire Not MRI conditional	1.50	2.80	1.60	1015 013

MATERIAL: PURE TITANIUM (ASTM F67)	ID mm	OD mm	LENGTH mm	REF
Size 0	1.00	2.00	1.60	1015 036
Size 1	1.25	2.55	1.60	1015 030
Size 1 with wire Not MRI conditional	1.25	2.55	1.60	1015 031
Size 2	1.50	2.80	1.60	1015 032
Size 2 with wire Not MRI conditional	1.50	2.80	1.60	1015 033

Packing unit 10 pieces/box

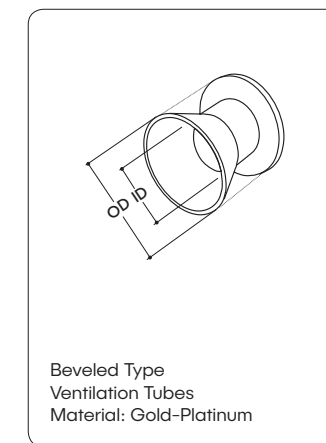

Beveled Type Ventilation Tubes
Material: Gold-Platinum

MATERIAL: GOLD-PLATINUM	ID mm	OD mm	LENGTH mm	REF
Size 0	0.75	1.60	0.70	1015 051
Size 1	1.25	2.55	1.50	1015 053
Size 2	1.50	2.80	1.50	1015 055

Packing unit 10 pieces/box

TVT TROCAR VENTILATION TUBES

ADEQUATE FIT WITHOUT PARACENTESIS

The Trocar Ventilation Tube is easy to insert without prior paracentesis. The tympanic membrane is pierced with the trocar tip upon which the ventilation tube is mounted. Once the trocar has been extracted, the ideal size between the incision and ventilation tube ensures that the ventilation tube is optimally fitted in the tympanic membrane. Insertion can be conducted easily and quickly under local anesthesia.

LARGE LUMEN FOR GOOD VENTILATION

The comparatively large inner lumen of the ventilation tube is an advantage allowing aspiration of secretion directly after insertion. The ventilation tube is therefore also suited for long-term ventilation and drainage of the middle ear and facilitates secretion discharge.

PURE TITANIUM

The Trocar Ventilation Tubes made of pure titanium have excellent tissue tolerance.

The Trocar Ventilation Tube is delivered readily mounted on a single use trocar tip. This tip is connected to the fitted reusable stainless steel hand piece, Trocar Handle.



Trocar Ventilation Tube



Trocar Handle

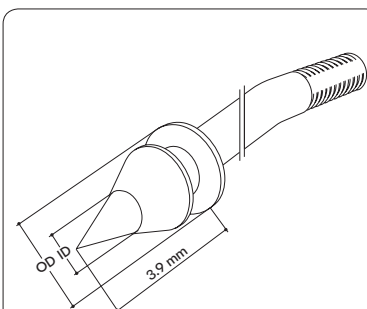

Trocar Ventilation Tubes (TVT)
Material:
Gilded Silver
Pure Titanium (ASTM F67
Medical Grade)

MATERIAL: GILDED SILVER	ID mm	OD mm	LENGTH mm	REF
Trocar Ventilation Tube	1.25	2.80	2.50	1015 074

MATERIAL: PURE TITANIUM (ASTM F67)	ID mm	OD mm	LENGTH mm	REF
Trocar Ventilation Tube	1.25	2.80	2.50	1015 075

Packing unit 10 pieces/box

REQUIRED ACCESSORY INSTRUMENT	REF
Trocar Handle stainless steel, resterilizable	8000

VENTILATION TUBE WITH EYELETS

EYELETS FOR LONG TERM VENTILATION

The Eyelet tube, based on the Tuebingen Ventilation Tube, is designed for long term ventilation and is manufactured with either one or two eyeleted medial flanges. The lateral flange displays orientation indentation to easily locate medial side flange placement.

GOOD VENTILATION

The eyelet tube is made of gold-platinum composition. The wider 1.50 mm inner diameter should offer additional dimensional benefit from occlusion along with a smoother lumen surface for efficient drainage.

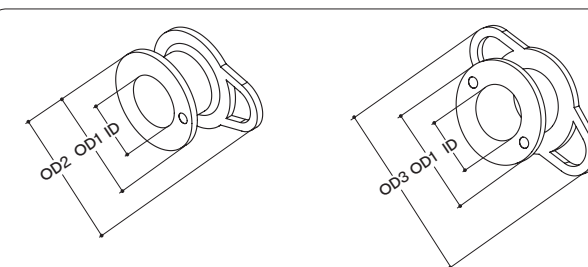

Ventilation Tube
with Eyelets / long-term
Material: Gold-Platinum

Diameter with Eyelets
1 Eyelet (OD2): 3.80 mm
2 Eyelets (OD3): 4.80 mm

MATERIAL: GOLD-PLATINUM	ID mm	OD1 mm	LENGTH mm	REF
Ventilation Tube (1 Eyelet)	1.50	2.80	1.60	1015 064
Ventilation Tube (2 Eyelets)	1.50	2.80	1.60	1015 065

Packing unit 10 pieces/box

MINIMAL TYPE VENTILATION TUBE

FOR TEMPORARY VENTILATION

The Minimal Type Ventilation Tube is particularly suitable for temporary ventilation of the middle ear in adults with acute tubal occlusion.

NO PARACENTESIS THANKS TO SHARPLY GROUND CANNULA

Thanks to its sharp medial end the Minimal Type can pierce the tympanic membrane directly. Typically, these tubes are placed under local anesthesia in clinic setting and no prior paracentesis is required. The Minimal Type Ventilation Tube remains in the tympanic membrane for periods ranging from a few days to several weeks. To avoid injuries the tube must be clinically removed.

GOLD COATED STAINLESS STEEL

KURZ manufactures the Minimal Type Ventilation Tubes from gold coated stainless steel.

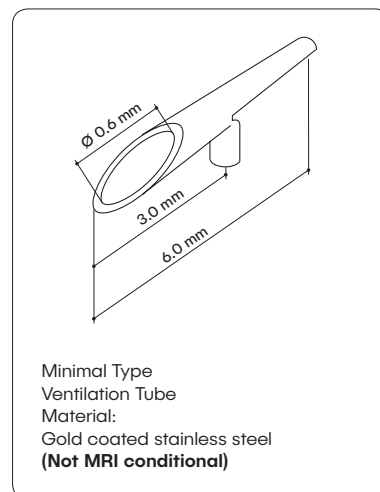

MATERIAL: GOLD COATED STAIN- LESS STEEL (Not MRI conditional)	ID mm	OD mm	LENGTH mm	REF
Minimal Type Ventilation Tube	0.60	0.90	6.00	1015 072

Packing unit 10 pieces/box

INSTRUMENTS AND ACCESSORIES



KURZ INSTRUMENTS FACILITATE IMPORTANT MANIPULATIONS

To facilitate the insertion of prostheses, ventilation tubes, or important manipulations, the surgeon can dispose over numerous resourceful KURZ solutions.

These include the KURZ Cartilage Cutter which enables precise cartilage slices cut with thicknesses ranging from 0.1 to 0.7 mm and the KURZ Meter for precise length determination of a stapes prosthesis.

STANDARDIZATION OF IMPORTANT SURGICAL STEPS

KURZ instruments are straightforward to handle. They standardize important surgical steps, such as coupling of a CiIP Stapes Prosthesis, or measuring the correct prosthesis length, aiming to shorten operating time and achieve optimized operation result. While the precision instruments are ideal in combination with KURZ implants, they can also be universally employed in ENT surgery.

HIGH PRECISION IN THE MANUFACTURING PROCESS

Stainless steel or titanium form the basis for KURZ instruments. Their production requires high precision and technical know-how.

TYMPANOPLASTY



TTP-VARIAC System Accessories



AC sizer System, sterile Single-use Sizers



KURZ Precise Cartilage Knife



Cartilage Forceps Schimanski Design



Sizer OMEGA CONNECTOR



Cartilage Punch incl. Instrument Tray

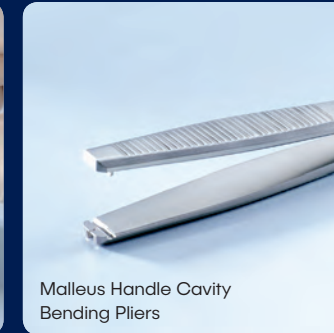

Malleus Handle Cavity Bending Pliers



BELL Expander

STAPEDIOPLASTY



KURZ Meter incl. Instrument Tray



Soft CiIP Hook

VENTILATION TUBES



Ventilation Tube Insertion Forceps

TTP-VARIAC® SYSTEM ACCESSORIES

ACCESSORY SET IN A PRACTICAL TRAY

TTP-VARIAC adjustable prostheses do require the use of VARIAC accessory instruments for proper execution of the assembly steps.

TITANIUM TWEEZERS FOR GENTLE PROSTHESIS HANDLING

The KURZ Titanium Tweezers are used for gentle removal and gentle handling of the prosthesis. They consist of pure material composition.

EXTREMELY ELEGANT MICRO SCISSORS

TTP-VARIAC Sizers, which are attached to the practical AC^{sizer} disk, determine the appropriate length of prosthesis (see page 10-11). With the aid of the Micro Scissors the surgeon can cleanly remove the sizer providing most optimal handling for length determination.

MICRO CLOSING FORCEPS FOR SECURE FIXATION OF VARIABLE-LENGTH PROSTHESES

The head plate of the adjustable length TTP-VARIAC Prosthesis must be securely fixed to the stem with the aid of the titanium Micro Closing Forceps. These forceps are custom engineered to precisely close the headplate onto the corresponding stem. The use of the specially developed instrument is compulsory for this step.

SPECIALLY DEVELOPED CUTTING FORCEPS

Use of the Cutting Forceps is also compulsory for the last step of the procedure. The tool trims the redundant stem from the lateral surface of the head plate. This leaves a small pin that, when the prosthesis has been inserted, fixates graft material such as cartilage or fascia between the implant and the tympanic membrane.

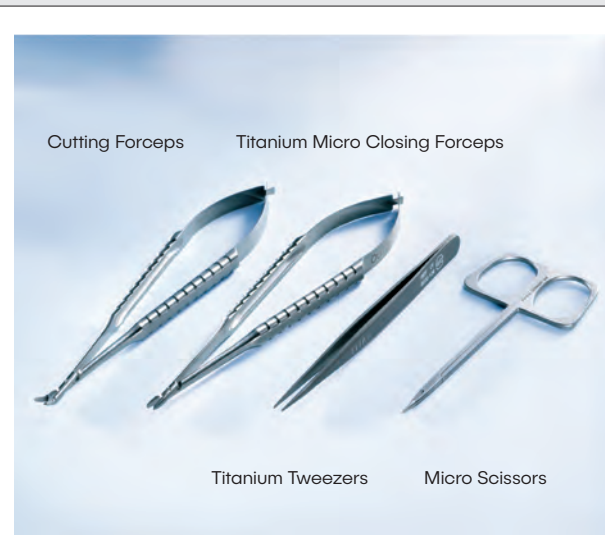

Tray TTP-VARIAC

ITEM	REF
Titanium Tweezers	8000 136
Titanium Micro Closing Forceps	8000 137
Cutting Forceps, stainless steel	8000 171
Micro Scissors, stainless steel	8000 172
Tray TTP-VARIAC (without instruments)	8000 173

Material:
Titanium, resterilizable
Sterilizable instrument quality
stainless steel

TTP-VARIAC System see page 10-11

AC^{sizer} SYSTEM SINGLE-USE SIZERS

APPROPRIATE PROSTHESIS LENGTH

Consistent and accurate sizing of a prosthesis is critical for postoperative hearing results: A prosthesis that is too short involves the risk of implant dislocation or migration. A prosthesis that is too long, can cause undesirable strain to the sensitive annular ligament of the stapes footplate.

TWO VERSIONS OF SIZING DISK

KURZ has developed a precision measuring system specially for determining the length of TTP-VARIAC Prostheses. With the aid of various sizers, which are attached to a practical disk, the surgeon can quickly and reliably determine the length of the prosthesis.

Two versions of sizing disks are available:

- 8 sizers for total prosthesis
- 6 sizers for partial prosthesis

FEATURES FOR SIMPLIFIED INTRAOPERATIVE HANDLING

Simple intraoperative handling of sizers is ensured by their light weight and ideal balance. In addition, elegant design provides optimal visibility.

On the back of the disk there are templates to determine the minimum size of transplants - e.g. cartilage or fascia - for the placement between the tympanic membrane and the prosthesis. The disk for partial prostheses also features a device for expanding the bells of BELL Prostheses.

Each disk is packed singly in sterile packaging. Each practical dispenser box contains 10 sizer disks.

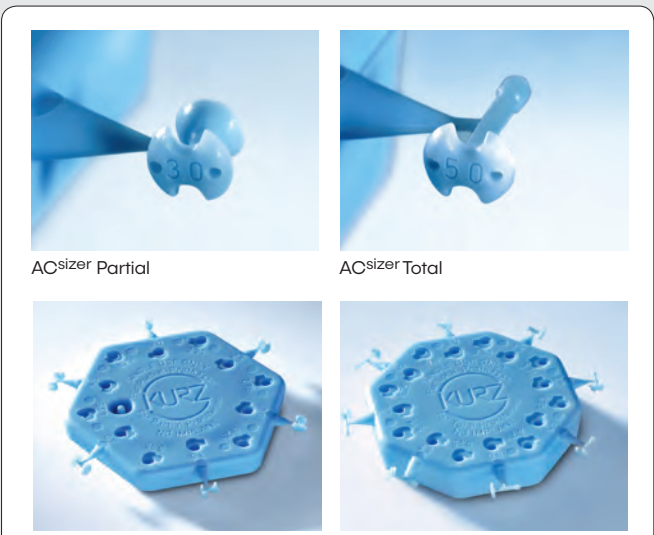

AC^{sizer} Partial

AC^{sizer} Total

AC^{sizer} Disk Partial

AC^{sizer} Disk Total



Dispenser Box (Unit 10 pieces/box)



Micro Scissors



Titanium Tweezers

OPTIONAL ACCESSORIES	REF
Titanium Tweezers	8000 136
Micro Scissors, stainless steel	8000 172



ITEM	REF
AC ^{sizer} System Partial sterile, Unit 10 pieces/box	8000 540
AC ^{sizer} System Total sterile, Unit 10 pieces/box	8000 550

Important note: The AC^{sizer} System is made of polypropylene and is only for temporary use during middle ear surgery.

KURZ® PRECISE CARTILAGE KNIFE

FOR CUTTING CONSISTENTLY THIN CARTILAGE SLICES

The KURZ Precise Cartilage Knife facilitates the cutting of consistently thin cartilage slices, as required for occluding tympanic membrane defects, covering tympanoplasty prostheses, or for reconstruction of the posterior auditory canal wall. It is equally suitable for cutting tragal and conchal cartilage conserving specimen material.

CARTILAGE SLICES AS FINE AS 0.1 MM

The cutting block, blade holder, and blade of the KURZ Precise Cartilage Knife make up a functional unit with which 0.7 mm cartilage slices can be made easily, quickly and in a standardized fashion. Distance plates (0.1/0.2/0.3 mm) make it possible to produce cartilage slices in thicknesses ranging from 0.1 mm to 0.7 mm.

The surgeon achieves best possible results with KURZ blades. Each blade is individually packed sterile in boxes of 10 each. They are particularly sturdy and contain one oval and one circular template imprinted on each blade face. The latter indicates the minimum size of graft for covering a KURZ tympanoplasty prosthesis.



Blade with template for graft size determination



KURZ Precise Cartilage Knife in Instrument Tray

ITEM	REF
KURZ Precise Cartilage Knife Set (blade holder, cutting block, distance plates, blades) incl. Instrument Tray	8000 155
Distance Plate for Precise 1mm (for compression of fascia)	8000 105
Supplies	REF
Blades sterile single packed, 10 pieces	8000 140

Material:
Sterilizable instrument quality stainless steel

Replacement Parts	REF
1 Set of Distance Plates (0.1/0.2/0.3 mm)	8000 102
KURZ Precise Blade Holder incl. Knurled Screw M3, St. 1.4305	8000 103
Instrument Tray KURZ Precise	8000 177
Knurled Screw M3, St. 1.4305	8000 190
Nut Precise Cutting Block M6	8000 191
KURZ Precise Cutting Block incl. Nut Precise Cutting Block M6	8000 110
Instrument Tray KURZ Precise incl. Plate POM+Tray stainless steel	8000 144

CARTILAGE FORCEPS SCHIMANSKI DESIGN

FOR DIFFERENT SIZES OF CARTILAGE SLICES

Different sizes and thicknesses of cartilage slices can be required for the management of minor tympanic membrane defects (myringoplasty), covering a tympanoplasty prosthesis, reconstruction of the auditory canal wall, or mastoidectomy. These can be made efficient and fast with the Cartilage Forceps.

FLEXIBLE HANDLING

The two rectangular jaws of the forceps hold the cartilage enabling reliable and precise cutting with the aid of a blade. Additional thinning can be achieved by repeating the primary technique. Consequently, the Cartilage Forceps facilitate conserving specimen material.

EFFICIENT AND STANDARDIZED METHOD

The Schimanski design cartilage forceps are an easy, efficient tool which simplifies the technique of trimming cartilage to functional specimen.

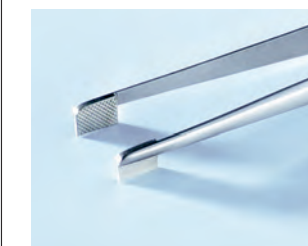

Rectangular jaws for gripping the cartilage



Slicing a piece of cartilage with a scalpel

ITEM	REF
Cartilage Forceps Schimanski Design	8000 193

Material:
Sterilizable instrument quality stainless steel

CARTILAGE PUNCH

ADDITIONAL STABILITY AND OPTIMIZED FIT

With the aid of a stabilizing shoe made of cartilage a total prosthesis can be positioned centrally and retained on the stapes footplate. In this way the surgeon counteracts a potential postoperative dislocation.

SINGLE-STEP PROCEDURE

KURZ developed the Cartilage Punch in an effort to reproduce a more consistent option for stabilizing of total prostheses. The instrument enables the surgeon to make small oval cartilage slices intraoperatively, swiftly, and in a single step. The center perforation is intended for the stem of KURZ Total Prostheses.



The punching procedure

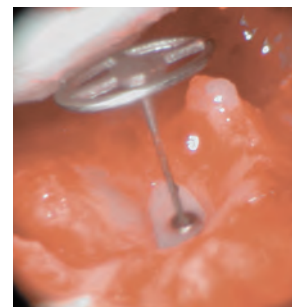

Total Prosthesis in-situ

Image courtesy of K. B. Hüttenbrink, Cologne, Germany



Cartilage Punch in Instrument Tray

ITEM	REF
Cartilage Punch incl. Instrument Tray	8000 200
REPLACEMENT PARTS	REF
Instrument Tray incl. Inlay	8000 176
Spring	8000 198
Plastic Base POM (black)	8000 207

Material:
Sterilizable instrument quality stainless steel

SIZER OMEGA CONNECTOR

SECURE CONNECTION WITH THE STAPES FOOTPLATE

The OMEGA CONNECTOR (see page 18-19) creates an optimized connection with the stapes footplate for KURZ Total Prostheses (with the exception of the Regensburg Total Prosthesis). To obtain a secure fit on the stapes footplate appropriate spatial conditions must be considered.

PRECISION REFERENCE MEASUREMENT

The Sizer OMEGA CONNECTOR was developed for managing the spatial limitations. Length and width of its measuring tip are equivalent to the dimensions of the KURZ OMEGA CONNECTOR.

EASY TO USE

The instrument is placed onto the footplate to determine ample footplate space for the OMEGA prosthesis. It is made of stainless instrument steel and can be resterilized.

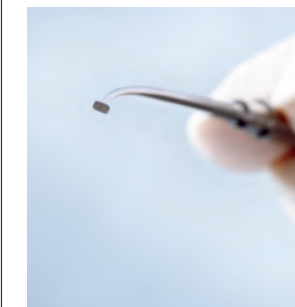

Measuring Head of Sizer OMEGA CONNECTOR

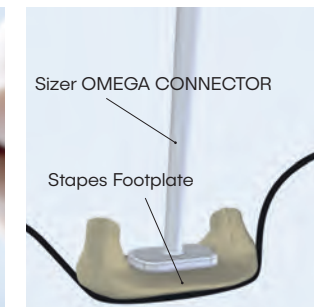

Sizer OMEGA CONNECTOR on Stapes Footplate

ITEM	REF
Sizer OMEGA CONNECTOR	8000 555

Material:
Sterilizable instrument quality stainless steel

MALLEUS HANDLE CAVITY BENDING PLIERS

MALLEUS HANDLE CAVITY TO COUNTERACT PROSTHESIS DISLOCATION

For easy intraoperative handling and a good postoperative hearing outcome, implant stability and implant balance are two of the most important criteria.

In this context it can be advantageous, to make a malleus handle cavity like the one found in the KURZ Malleus Notch implant. It ensures good prosthesis fit and thus counteracts the risk of dislocation.

FOR A LARGE NUMBER OF TYMPANOPLASTY PROSTHESES

With the aid of the Malleus Handle Cavity Bending Pliers a surgeon using KURZ tympanoplasty prostheses (TTP-Tuebingen Type, Duesseldorf Type, TTP-VARIO or TTP-VARIAC) can make an optional malleus handle cavity to the existing head plate. The pliers standardize and speed up this procedure.

GENTLE CONSISTENT PRESSURE

A special holder at the tip of the pliers holds the implant securely during the bending process. The concavity can thus be created with gentle, consistent pressure.



ITEM	REF
Malleus Handle Cavity Bending Pliers	8000 109

Material:
Sterilizable instrument quality stainless steel

BELL EXPANDER

INDIVIDUAL ALIGNMENT AND EXPANSION OF THE PROSTHESIS

Elegant designs make it possible to adapt KURZ middle ear prostheses to unique anatomical conditions by bending. Stems are easily angulated and bells can be modified to a more open position in the presence of enlarged capitulum adding to a more consistent predictable sizing.

ADAPTATION TO THE STAPES HEAD

For individual expansion of the bell on partial prostheses, KURZ offers a special BELL Expander. This tool uniformly expands any KURZ BELL implant to fit unique dimension of stapes heads while preserving the integrity of the materials. Consequently, the implanted prosthesis is fitted securely and the anatomically shaped bell can transmit incoming sound directly to the articular surface of the stapes.

THUMBSCREW RESTRICTS EXPANSION

The degree of expansion is adjusted by using a thumbscrew on the head of the BELL Expander. The prosthesis stem is positioned into the special slot, whereby the bell is pointing upward. A tapered pin exerts uniform pressure on the bell and expands it gently.

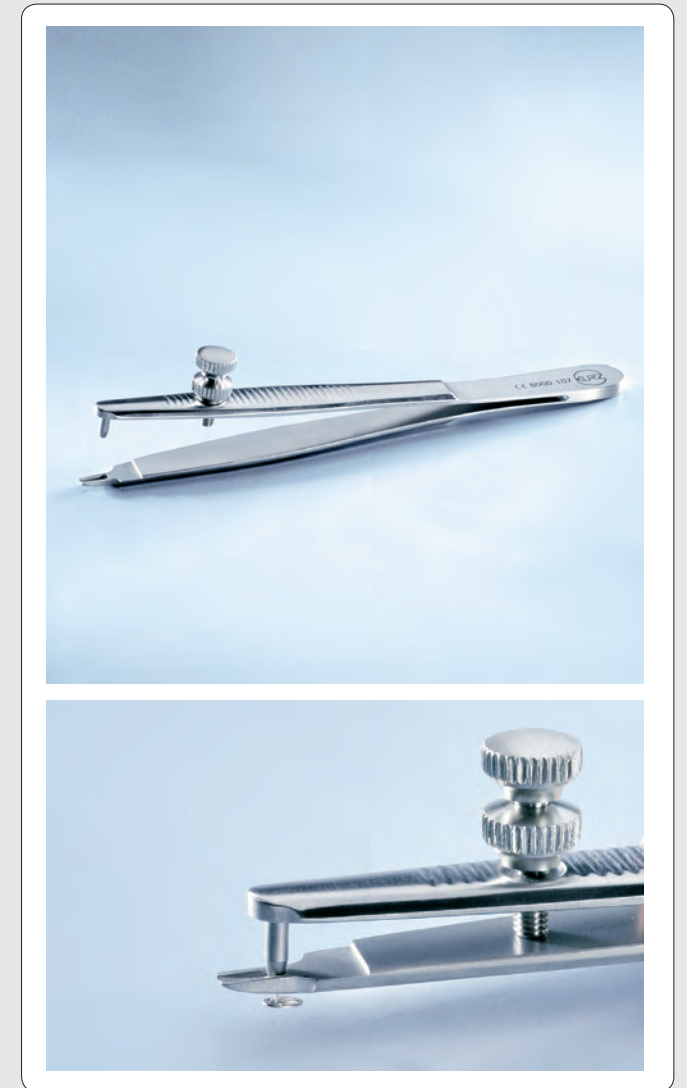

ITEM	REF
BELL Expander	8000 107

Material:
Sterilizable instrument quality stainless steel

PRECISION STAPES PROSTHESIS LENGTH DETERMINATION

The KURZ Meter is a precision instrument for determining the length of stapes prostheses intraoperatively. Due to its easy handling it simplifies and standardizes the measuring procedure during stapes surgery.

MORE SAFETY

A scale on both sides allows easy use for right- and left-handed users. The stop hook of the KURZ Meter is applied medially to the long process of the incus. With the aid of a slide the surgeon advances the measuring tip up to the footplate with precision. Prosthesis length is calculated by adding the measured distance between the process of the incus (medial side) and the surface of the stapes footplate to the depth of prosthesis insertion into the inner ear. The latter is determined by the surgeon.

SAFE CLEANING AND STERILIZATION

The KURZ Meter can be disassembled into its individual parts for safe cleaning. This facilitates sterilization.



Measured distance is read off the scale reliably

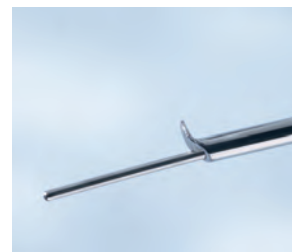

Measuring tip with stop hook



KURZ Meter in an Instrument Tray

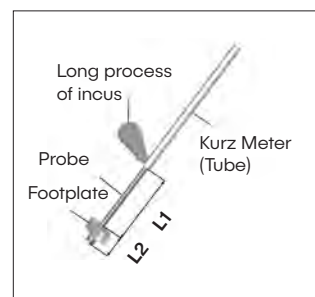

Measuring of Prosthesis Length

L Prosthesis = L 1 + L 2
 L 1 = Measured distance
 L 2 = Immersion depth* (Piston)

*The determination of the immersion depth L2 of the prosthesis is subject to the decision of the surgeon.

ITEM	REF
KURZ Meter incl. Instrument Tray	8000 106

ITEM	REF
Instrument Tray	8000 174

Material:
 Sterilizable instrument quality stainless steel

EASY INSERTION OF CLIP STAPES PROSTHESES

KURZ developed the Soft CliP Hook specially for standardized insertion of NiTiFLEX and Soft CliP Stapes Prostheses. While the prosthesis shaft is positioned in the open footplate the CliP prosthesis is gently pushed onto the long process of the incus with the aid of the Soft CliP Hook. This reduces the risk of movement toward the direction of the inner ear and undesirable rotation of the prosthesis.

REDUCED FORCE REQUIRED

The Hook securely holds in place the special recess of the loop while pushing. It permits gentle attachment of the CliP prosthesis with reduced force. The application force is transferred to the axis of the long process of the incus.

Developed in close collaboration with Dr. John W. House, House Ear Institute, Los Angeles, USA.

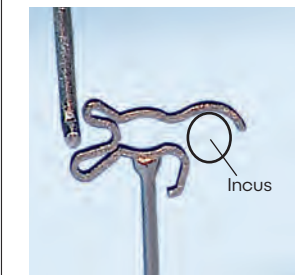
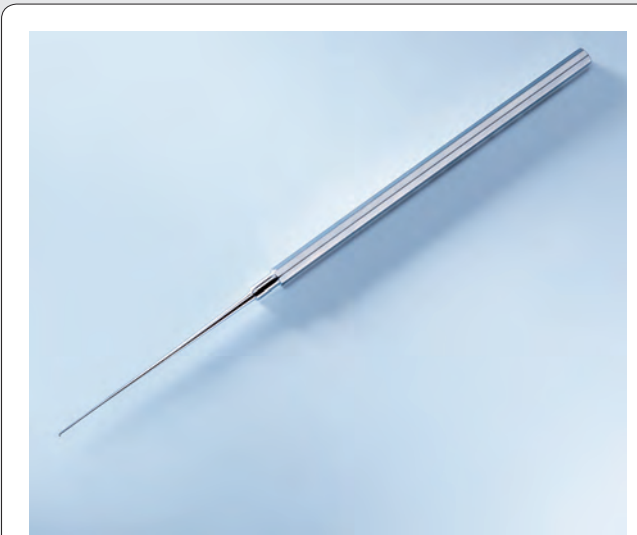

Positioning onto the incus with the first wide opening

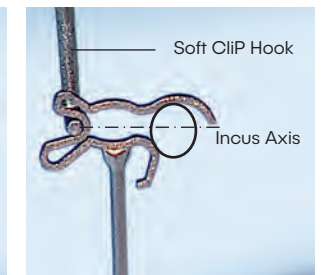

Prosthesis is pushed into place with one movement

Image courtesy of G. Schimanski

Image courtesy of G. Schimanski

ITEM	REF
Soft CliP Hook	8000 127

Material:
 Sterilizable instrument quality stainless steel

VENTILATION TUBE INSERTION FORCEPS

FOR RETENTION COLLAR VENTILATION TUBES

KURZ has developed a special instrument for inserting ventilation tubes with a retention collar: the Ventilation Tube Insertion Forceps. It particularly facilitates the handling of Tuebingen Type Ventilation Tubes, Ventilation Tubes with Eyelets, and Beveled Type Ventilation Tubes.

TRANSPORT AS SAFE AS POSSIBLE

The holding mechanism of the insertion instrument immobilizes the tube during transport and thus facilitates insertion of the ventilation tube in the tympanic membrane. The tube remains on the shaft of the Insertion Forceps until it is finally released. The instrument is made of stainless, resterilizable instrument steel.

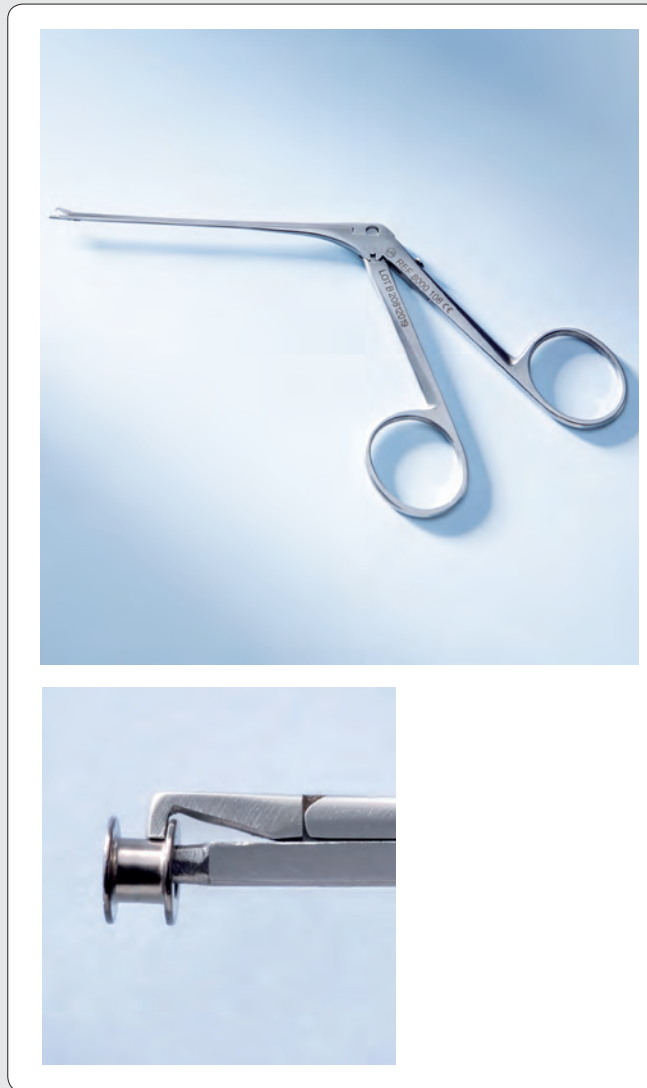

ITEM	REF
Ventilation Tube Insertion Forceps	8000 108

Material:
Sterilizable instrument quality stainless steel

Prescription Devices

Caution: United States Federal Law restricts devices identified herein to sale by or on the order of a physician. This brochure does not replace nor does it set forth the complete contents of the "Instructions for Use" for the products in this brochure, and is not a substitute for reviewing and understanding that important information. Therefore, before using any products included in this brochure, please review the entire contents of the respective "Instructions for Use" information.

Because of registration the products are currently not available in all countries.



Heinz Kurz GmbH Medizintechnik
Tuebinger Strasse 3 | 72144 Dusslingen | Germany
Phone: +49 (0)7072/9179-0 | Fax: +49 (0)7072/9179-79
E-Mail: info@kurzmed.com | www.kurzmed.com

KURZ Medical, Inc.
5126 South Royal Atlanta Drive | Tucker, GA 30084 | USA
Toll Free Order #: 866.449.8020 | Phone: 770.349.6330
Fax: 770.934.3384 | E-Mail: info@kurzmed.com
www.kurzmed.com

12/2016-M9600320



MIDDLE EAR INTELLIGENCE